

**G** **PERFORMANCE**  
**GARED** **SPORTS SYSTEMS**

Single Post Ceiling Suspended Backstops

Models: 3102 thru 3115

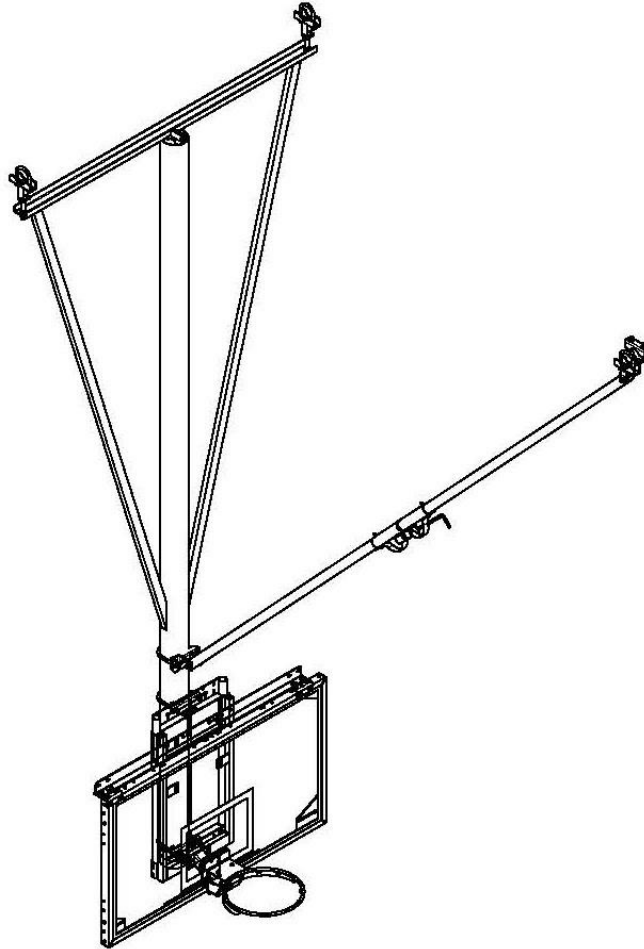

**Installation, Operation, and Maintenance Instructions**

.....  
**Please read all instructions before attempting operation of these units**  
.....

**SAVE THESE INSTRUCTIONS FOR FUTURE USE**

PUBLICATION No.  
501755500 Rev D

Issued  
12/26/2023

## ***Table of Contents***

<b><u>Section</u></b>	<b><u>Page No.</u></b>
Introduction	2
Recommended Tools and Tips	3
Model Definitions	4
Bolt Torque Chart	5
Parts Illustrations	6
Clamped Mast Assembly Instructions	9
Installation Instructions	11
Sliding Braced Units Brace Installation	13
Folding Braced Units Brace Installation	15
Folding Braced Units Alternate Brace Installation	16
Stationary Units Brace Installation	17
Wall Braced Units Brace Installation	18
Winch Installation and Cable Routing	19
Sliding Braced Units Cable Routing	20
Folding Braced Units Cable Routing	22
Board and Goal without Height Adjuster Installation	23
Board and Goal with Height Adjuster Installation	25
Folding Braced Units Brace Adjustment and Setting Limit Switches	27
Unit Operation	31
Maintenance	33

**⚠ WARNING**

READ, UNDERSTAND, AND FOLLOW ALL INSTALLATION NOTES AND INSTRUCTIONS AND ALL OPERATING INSTRUCTIONS OUTLINED IN THIS MANUAL.  
FAILURE TO FOLLOW THESE INSTRUCTIONS COULD RESULT IN DAMAGE TO EQUIPMENT AND OR SERIOUS INJURY TO PERSONNEL.

**Introduction**

This manual has been developed to provide you with important information regarding the installation, operation, and maintenance of your basketball backstops. Because each installation is unique to different building structures and configurations, you must follow the individual plans provided with the product for installation of the overhead supports for the backstops. This manual will assist you with key assembly issues of the backstop itself.

This equipment should only be installed by an authorized and trained installer who is experienced in the assembly and installation of gymnasium equipment.

Do not make substitutions for any factory parts. If any parts are missing, do not substitute non-factory parts. Please contact your authorized dealer or manufacturer if any parts are missing or damaged.

It is recommended that an individual who has been properly trained perform operation of these backstops. No one under the age of 18 should operate the backstop, unless properly supervised.

To prevent normal wear and tear from shortening the life of the backstop, preventative maintenance inspections and repairs should be performed at least once per year. If the backstop is subject to high or unusual usage, inspections should be scheduled to occur more frequently. If items are found to be nonconforming, replacements can be ordered from an authorized dealer. When contacting your dealer, please have information regarding the name of the project, and any applicable warranty information.

Please note that manufacturer assumes no responsibility for the building structure to support its products. It is the responsibility of the building designers to determine the correct structure size to support our products. We will provide your structural engineers with all required weight and loading information for the project in order for them to calculate the appropriate structure.

### Recommended Tools

Tools Required:

Hard-Hat, Safety Glasses, Steel Toed Work Boots

Scaffolding or Electric Scissor Lift

Plumb Bob or Laser Plumb Bob

Laser Tape Measure or 100' tape measurer along with a 25' tape measurer

Chalk Line

Socket Set

Wrenches

Impact Tools

Allen Wrench Set

Screwdrivers (Standard and Phillips)

Needle-nose pliers

Straight edge screwdriver

Ratchet with sockets

Bubble Levels

Drill w/bits

Reciprocating Saw or Band Saw

Block and Tackle/ Chain Hoist

Wire Cutters

Torque Wrenches: 5-75 Ft-Lbs. and 30-150 Ft-Lbs.

### Installation Tips

1. Make sure the installation area is clear of any debris.
2. Protect any finished floor surface.
3. Preassembly of the Backstop on the mast is recommended but not required.
4. **USE EXTREME CAUTION WHEN HOISTING THE MAST!!**
5. Beam Clamps need to be sitting flat and square to the beam.
6. Follow your detailed project drawings from the manufacturer, which will tell you everything from, exact product and part locations to exact clamp locations.
7. Following the manufacturer's prints, mark out superstructure on the floor using a chalk line. Next transfer those lines using a laser plumb bob or standard plumb bob.
8. Before you start assembly, distribute parts to the correct backstop locations.
9. All equipment is supplied with Grade 5 hardware. All Clamps are designed to be installed with the nuts and bolts "tight" and torqued to the required torque, except as noted otherwise in this manual or the installation prints.
10. Bolted hinge joints are generally not torqued to a specific value. Refer to the specific tightening instructions noted in the manual and installation prints for all hinge components.

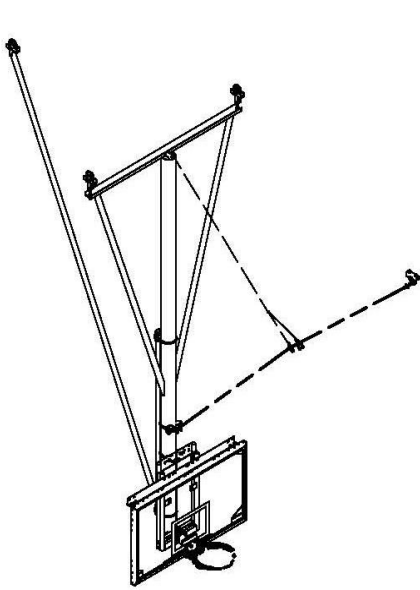

Model 3102 & 3103

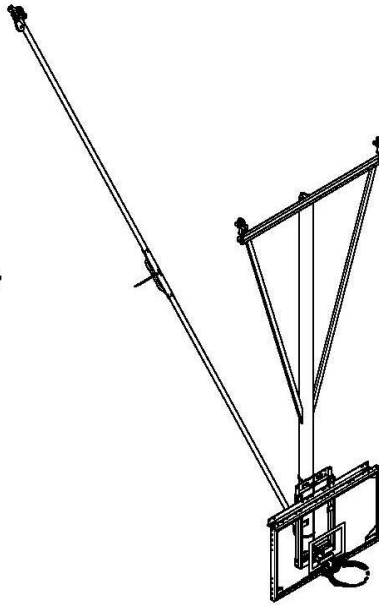

Model 3104 & 3105

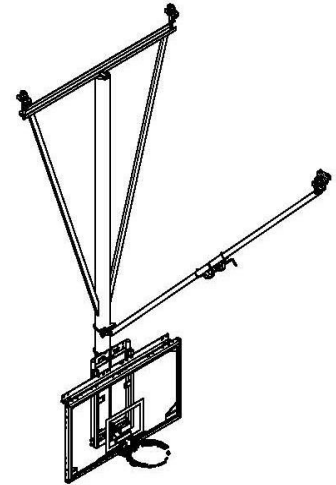

Model 3106, 3107, 3108, & 3109

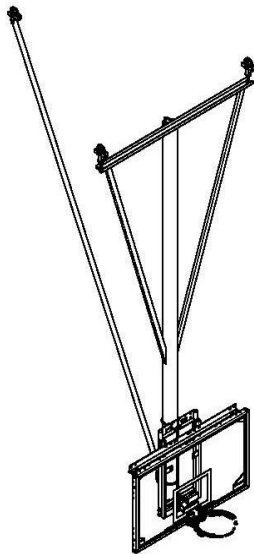

Model 3110 & 3111

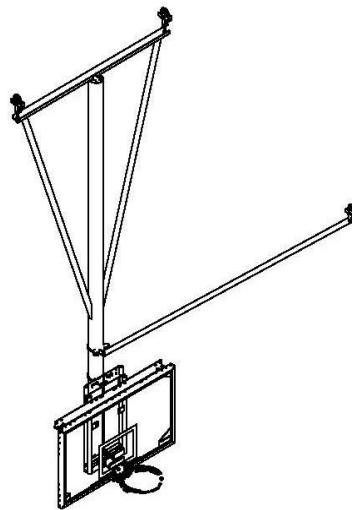

Model 3112 & 3113

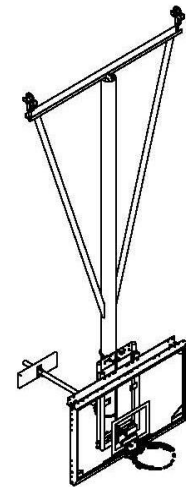

Model 3114 & 3115

Models 3102 & 3103 are rear braced front folding  
Models 3104 & 3105 are rear braced rear folding  
Models 3106 & 3107 are front braced front folding  
Models 3108 & 3109 are side braced side folding  
Models 3110 & 3111 are rear braced stationary  
Models 3112 & 3113 are front braced stationary  
Models 3114 & 3115 are wall braced stationary

Note: Odd numbered models are welded mast units while the even numbered models are clamped mast units.

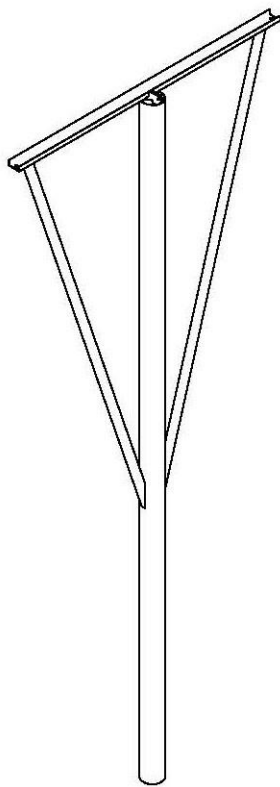

WELDED MAST

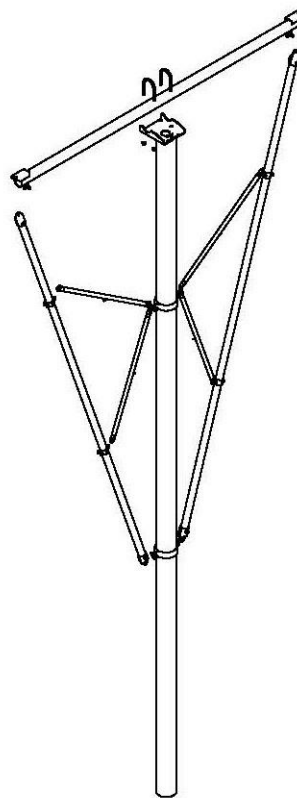

CLAMPED MAST

During installation, inspections, and required maintenance, it is important to make sure all bolted connections are properly torqued. The chart below shows the proper torque for fasteners used in this product. All fasteners should be torqued to the values indicated in the chart unless a fastener has a specific torque noted in the instructions or the production prints.

RECOMMENDED BOLT TORQUE				
Bolt Size	Wrench Size	In-Lbs	Ft-Lbs	Nm
1/4"	7/16"	66 to 90	5.5 to 7.5	8 to 10
5/16"	1/2"	132 to 180	11 to 15	15 to 20
3/8"	9/16"	234 to 318	19.5 to 26.5	27 to 36
7/16"	11/16"		31 to 42.5	43 to 58
1/2"	3/4"		47 to 65	64 to 88
9/16"	7/8"		68 to 90	93 to 122
5/8"	15/16"		94 to 130	128 to 176
3/4"	1-1/8"		166 to 230	226 to 312
7/8"	1-5/16"		269 to 372	365 to 504
1"	1-1/2"		402 to 566	546 to 767

**PARTS USED IN OVERHEAD STRUCTURE OF THE BACKSTOP**

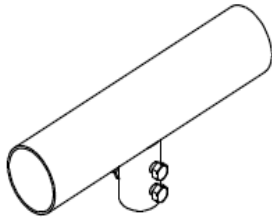

151651777  
KIT, 16" WELDED DROP PIPE

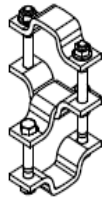

151655402  
CROSSOVER CLAMP ASSEMBLY

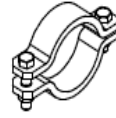

161655626  
STRAP CLAMP ASSY, 3.5" (#314)

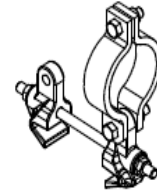

2313-02-08  
SWIVEL BEAM CLAMP

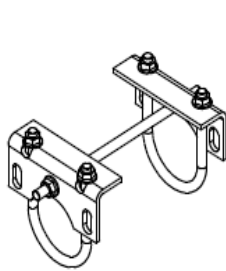

1684-02-08  
UNIVERSAL BEAM CLAMP ASSEMBLY-STAND

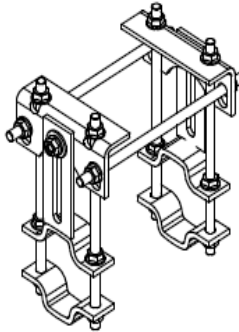

1694-02-08-8-STD-DBL  
ADJUSTABLE BEAM CLAMP  
(SPECIAL BOLT TORQUE)

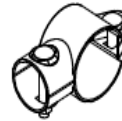

1141-02-08  
#141 TEE CLAMP. 2.38" TO 3.5"

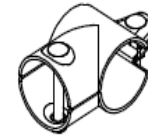

1150-02-08  
#150 TEE CLAMP. 3.5" TO 3.5"



1116-02-08  
#116 TEE CLAMP. 1.9" TO 2.38"



1035-09-00  
3 1/2" END CAP

**PARTS USED IN ATTACHMENT OF THE BACKSTOP**

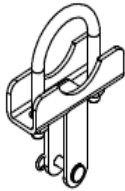

161655628  
SWING HANGER ASS'Y, 3.5" EXTENDED

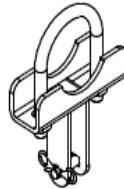

161655629  
TRAVEL HANGER ASSY, 3.5" EXTENDED



1448-11-08  
EYEBOLT ASSEMBLY, 7/8"-9 X 6"

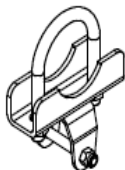

161655633  
CLAMP ASS'Y, 3.5 X 2.38 SWING HINGE

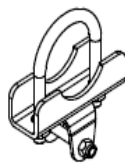

161655632  
CLAMP ASS'Y, 3.5 X 1.9 SWING HINGE

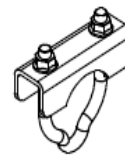

161655636  
PULLEY HANGER ASSEMBLY, 3.5"



1005-07-00  
#5 PULLEY

**IMPORTANT NOTE:**

-THIS PAGE SHOWS ALL PARTS THAT COULD BE USED WITH A BASKETBALL BACKSTOP

-ALL PARTS SHOWN ON THIS PAGE **MAY NOT** BE USED IN ALL INSTALLATIONS.

-BE SURE TO CHECK THE PARTS LIST ON THE PARTS COVER PAGE FOR THOSE PARTS TO BE USED IN THIS INSTALLATION

**PARTS USED IN ASSEMBLY OF THE BACKSTOP**

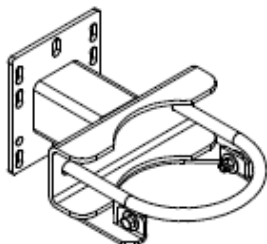

503951386  
DGA ASSY, 6 5/8" MAST W/ANTI-ROTA

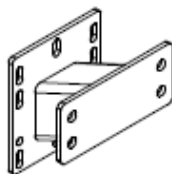

503853428  
WELDMENT, DIRECT MOUNT EXTENSION

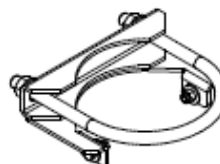

503951385  
CLAMP ASSY, AAG MOUNT, 6 5/8" ANTI-ROTA

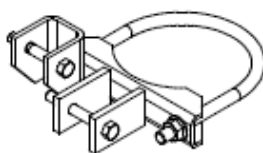

503855660  
MAST HINGE W/SAFESTOP, 1.9"

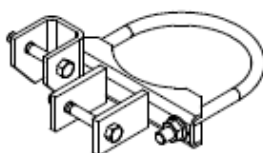

503855634  
MAST HINGE W/SAFESTOP, 2.38"

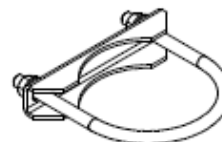

503854344  
BANK MOUNTING CLAMP, 6 5/8" ASSY

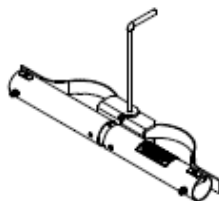

503955559  
2.38" ADJ BRACE HINGE ASSY W/BRKR

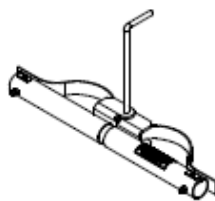

503955558  
1.9" ADJ BRACE HINGE ASSY W/BRKR

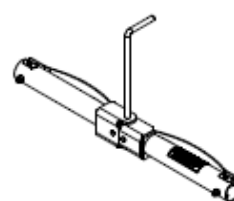

503951222  
1.9" ADJ BRACE HINGE ASSY , ZERO



1060-09-00  
6-5/8" RRC6 PLASTIC PIPE END CAPS



1092-02-08  
#92 STRAP CLAMP, 1.9"



5042-02-00  
1-7/8" MUFFLER CLAMP

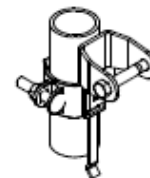

503955486  
SLIDE ROD BUSHING, 2.38" BRACE



1115-30-00  
3/8" QUICK LINK



101505744  
SMALL PULLEY SHEAVE



1280-30-00  
1/4" UNIVERSAL SNAP LINK

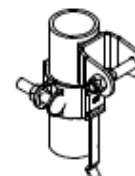

503953089  
SLIDE ROD BUSHING, 1.9" BRACE

**IMPORTANT NOTE:**

-THIS PAGE SHOWS ALL PARTS THAT COULD BE USED WITH A BASKETBALL BACKSTOP

-ALL PARTS SHOWN ON THIS PAGE **MAY NOT** BE USED IN ALL INSTALLATIONS.

-BE SURE TO CHECK THE PARTS LIST ON THE PARTS COVER PAGE FOR THOSE PARTS TO BE USED IN THIS INSTALLATION



**PARTS USED IN ASSEMBLY OF THE BACKSTOP**



3125-30-00  
1/4" CABLE THIMBLE

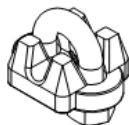

3225-30-00  
1/4" CABLE CLAMP (FORGED CLIP)

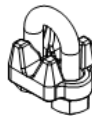

3213-30-00  
3/16" CABLE CLAMP (FORGED CLIP)



3109-30-00  
1/8" CABLE CLAMP

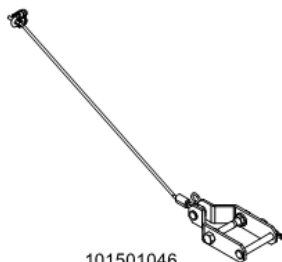

101501046  
GUIDE ASSY, SAFE STRAP RETRACTOR

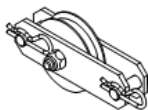

101505758  
SMALL PULLEY



503852349  
BRACKET, ADJUSTABLE BOARD MOUNT

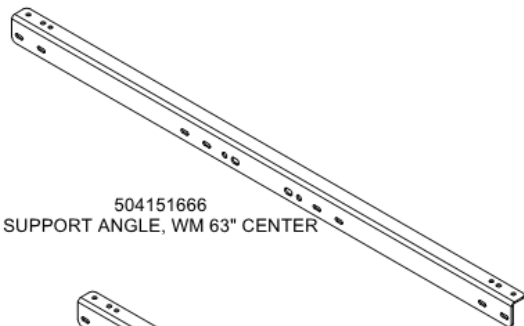

504151666  
SUPPORT ANGLE, WM 63" CENTER

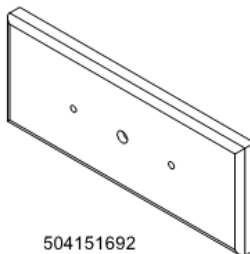

504151692  
WOOD PAD, 2"x 10"x 24" FU



123951579  
WARNING LABEL - MAST CABLE SLACK

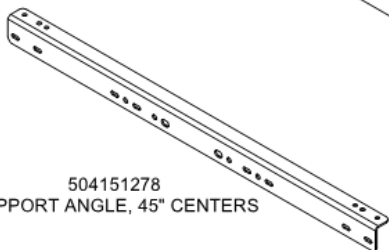

504151278  
SUPPORT ANGLE, 45° CENTERS

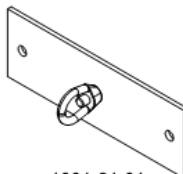

1001-21-01  
WALL MOUNT PLATE

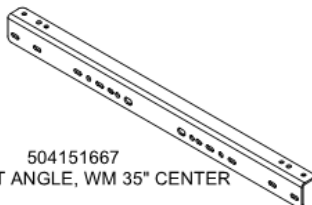

504151667  
SUPPORT ANGLE, WM 35" CENTER

**IMPORTANT NOTE:**

- THIS PAGE SHOWS ALL PARTS THAT COULD BE USED WITH A BASKETBALL BACKSTOP
- ALL PARTS SHOWN ON THIS PAGE **MAY NOT** BE USED IN ALL INSTALLATIONS.
- BE SURE TO CHECK THE PARTS LIST ON THE PARTS COVER PAGE FOR THOSE PARTS TO BE USED IN THIS INSTALLATION

**⚠ CAUTION**

BEFORE BEGINNING THE INSTALLATION, READ, UNDERSTAND, AND FOLLOW ALL SAFETY INSTRUCTIONS FOR POWER TOOLS AND EQUIPMENT. USE PROPER SAFETY EQUIPMENT DURING THE INSTALLATION.

**⚠ WARNING**

DO NOT SUBSTITUTE PARTS OR HARDWARE WITHOUT WRITTEN AUTHORIZATION FROM THE FACTORY.  
SUBSTITUTING INCORRECT PARTS OR HARDWARE COULD RESULT IN COMPONENT FAILURE, DAMAGE TO EQUIPMENT, OR INJURY TO PERSONNEL.

Follow the instructions provided in the production drawing package for installing the overhead supporting structure for the backstops. Make sure all overhead structure has been installed per the drawings and all connections are properly tightened before beginning the installation of the backstop. Check to make sure all beam clamps have been installed correctly and tightened properly before attaching the mast swing hangers to the overhead pipe.

BEAM CLAMP INSTALLATION PROCEDURE

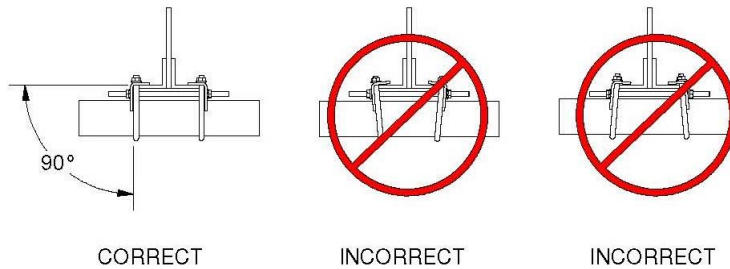

**Clamped Mast Assembly**

The following Parts List is shown as a reference to the following assembly instructions. You should always refer to the packing list for the specific job for the correct Part Numbers and quantities for your specific application.

Item	Part Number	QTY	Description
1	See Note	1	MAST WELDMT
2	See Note	1	SPREADER WELDMENT
3	2375-04-00PC	2	TUBE,RND,2.375 OD X 0.083 WALL (Sway Brace)
4	See Note	4	BRACE TUBE, X-SWAY
5	101051278	2	U-BOLT, 5/8" X 4" X 6-1/2"
6	1093-02-08	4	#93 STRAP CLAMP. 2.38"
7	2415-02-08	4	415 SWAY BRACE CLAMP ASSY
8	3002-02-08	2	CLAMP ASSY, 02 SWAY
9	502-8-13-32	2	HEX BOLT, 1/2-13 UNC X 2
10	548-10-11	4	HEX NUT, SERRATED FLANGE 5/8-11
11	548-8-13	2	HEX NUT, SERRATED FLANGE 1/2-13

Note: Part Number will vary based on Truss Height

Some installers prefer to install the clamped mast in pieces beginning with the spreader bar connected to the overhead and then adding the mast, sway braces, X-brace tubes, etc. While this method is acceptable, this manual will show the mast assembled on the ground in order to provide clarity to the bolted connections.

Begin by laying out the components of the mast on the floor in the configuration of the completed mast. Make sure all parts are ready for the assembly.

Install the spreader onto the mast using the two U-Bolts. Make sure the spreader is centered on the mast (or offset to the dimension shown in your specific job plans). Install the locknuts and tighten by hand.

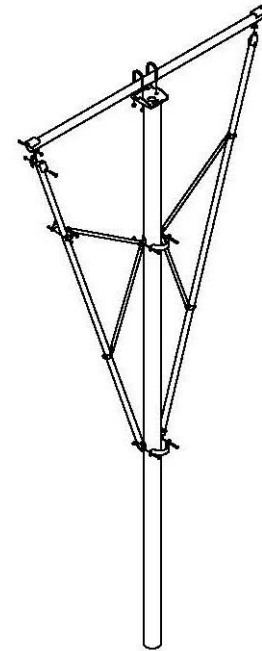
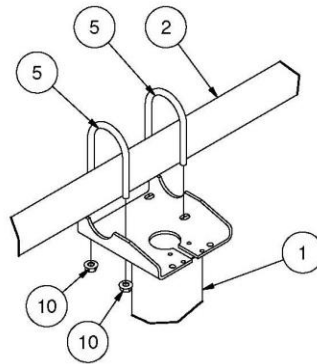

Rotate the spreader bar so that the holes for the 7/8" Eye-bolts are in line with the mast. If these holes are not lined correctly, the mast will not hang correctly when installed.

Once the holes are aligned, torque the U-Bolt nuts to the proper torque as outlined in the bolt torque chart.

Install the sway brace clamps onto the ends of the Sway brace tubes using the 1/2" x 3-1/2" carriage bolts and 1/2" whizlock nuts.

Torque these nuts to the appropriate torque.

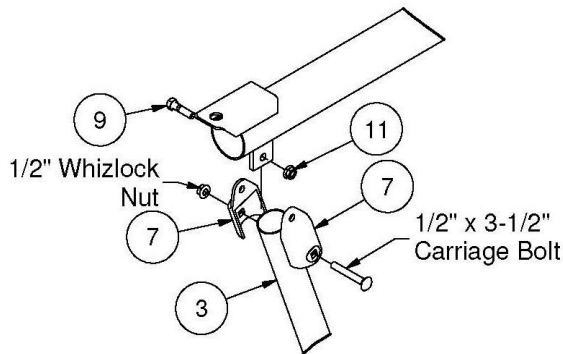

Install one end of the sway brace tube to the tab on the end of the spreader bar using the 1/2" x 2" hex bolt and 1/2" whizlock nut. Do not torque these bolts at this time.

Install the other sway brace tube on the tab at the opposite end of the spreader bar as before.

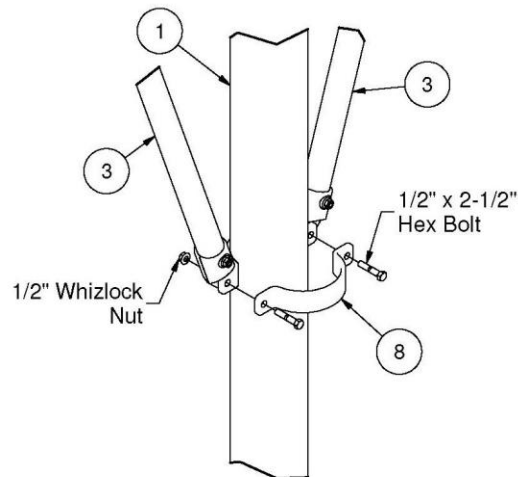

Install the sway clamp onto the mast tube and slide the end of the sway brace tube onto the sway clamp bolt. One sway brace tube on each side of the sway clamp.

Install the 1/2" whizlock nuts and tighten. Torque the clamp bolts to the appropriate torque. Return to the top of the mast and

torque the bolts connecting the top of the sway braces to the tabs on the spreader.

Depending on the truss height, your mast may have more than one set of x-braces. Check your specific job plans. This manual will show connection of one set of x-braces.

Additional sets of x-braces are connected the same.

Install a sway clamp assembly onto the mast tube approximately centered between the spreader and the lower connection of the sway braces. On each side of the clamp, attach the end of two of the x-braces install the 1/2" whizlock nut, but DO NOT tighten.

This clamp must remain loose at this time to allow for vertical adjustment in order to fit the other end of the x-brace tubes to the sway brace tubes.

Start with the upper x-brace on one side and fit it to the strap clamp on the sway brace.

Install the x-brace between the short sides of the strap clamp and secure with the 3/8" x 1-1/4" carriage bolt and 3/8" whizlock nut.

Install the 3/8" x 2" carriage bolt to the other side of the clamp and loosely tighten.

Repeat this for each of the remaining x-braces.

Adjust the position of the clamp on the mast to center the x-braces and align them equally in position.

Torque the sway clamp bolts and the strap clamp bolt to the appropriate torque as shown in the bolt torque chart.

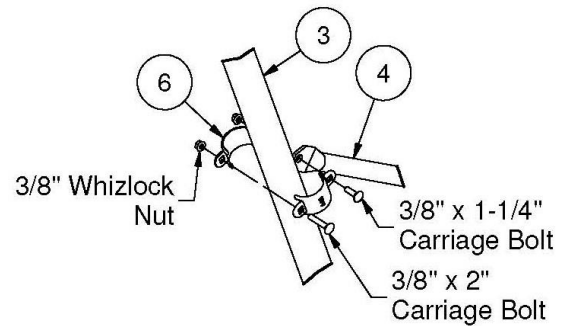
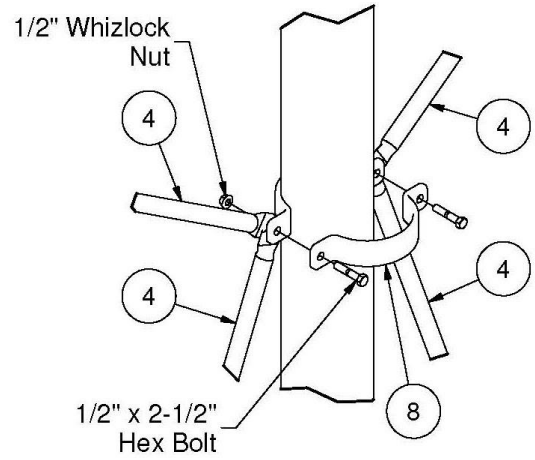

### Installing the backstops

At this point, the overhead structure for the backstop should be installed per the plans provided for the job and ready to accept the installation of the backstop. Recheck all connections of the overhead structure to make sure all beam clamps and bolted connections have been properly tightened and torqued.

Prepare the backstop by first installing the 7/8" forged eyebolts into the mast spreader.

Install the 7/8" eyebolts into each end of the spreader as shown in the illustration on the right. Note: Welded mast spreader shown.

Put a 7/8" hex nut onto the eyebolt and thread it on far enough to have approximately 3-1/2" of thread exposed. Add a 7/8" lock washer and then insert the eyebolt into the hole in the spreader.

Finish by installing another 7/8" lock washer and 7/8" hex nut. Tighten the lower nut by hand only at

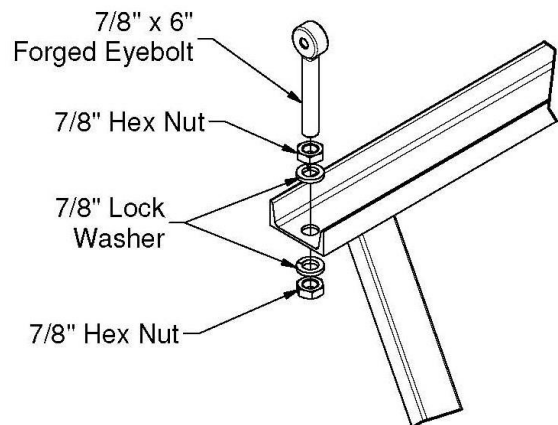

this time.

These nuts will be torqued when the mast is attached to the overhead swing hangers and leveled and plumbed.

Next install the swing hangers to the overhead structure.

Locate and mark the center of the mast on the overhead structure pipe using the plans provided for the job. Measure the backstop spreader distance between the centers of the 7/8" eyebolts.

Mark the overhead structure pipe 1/2 of the measurement on each side of the center of the mast mark.

Place a swing hanger on each of these marks with the U-Bolt on the mark. Install the swing hanger base and nuts and hand tighten.

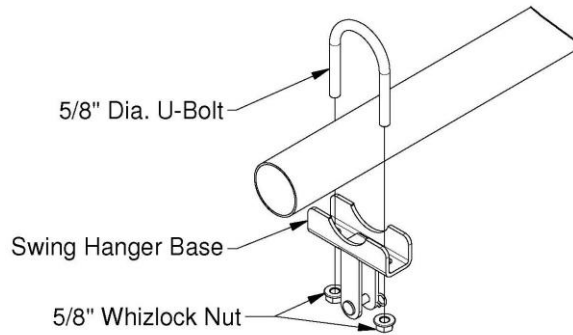

Before hoisting the mast, note the position of the offset on the mast. The mast offset should be facing the direction of fold to assist in locking the braces in the playing position unless noted differently on the installation drawings for the specific job.

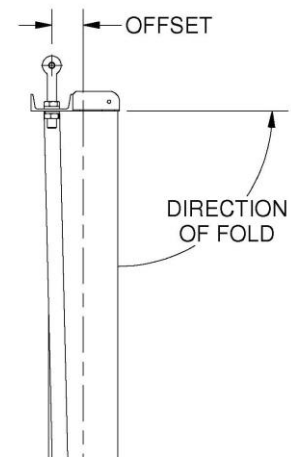

There are several methods to hoist the mast into position for attachment to the swing hangers. Block and tackle, chain hoist, electric hoist, etc. are some methods. You should use the safest and most reliable method available for your installation.

Always use extreme care when hoisting the mast and make sure there are no personnel below the mast during the lift.

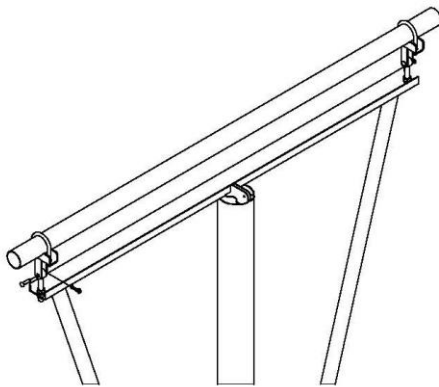

With the mast lifted in position to align the 7/8" eyebolt with the swing hanger attachment hole, insert the 1/2" x 2" clevis pin.

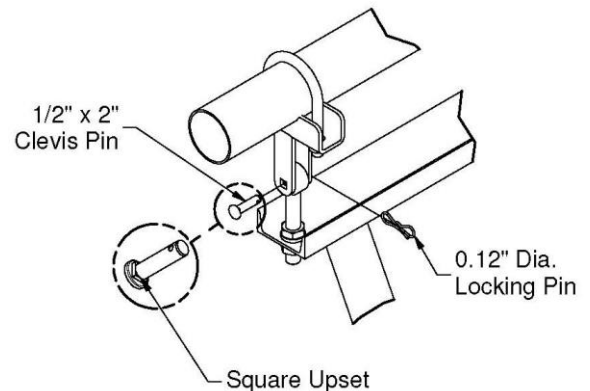

Make sure the square upset on the head of the clevis pin

fully engages the square hole on the swing hanger. Install the 1/8" diameter locking pin in the hole of the clevis pin to secure the joint.

Using a laser or plumb bob, verify the mast is centered on the proper location on the floor plan. If not, slide the swing hangers left or right to bring the center of the mast onto the centerline of the backstop location on the floor.

Torque all swing hanger U-bolt nuts. Check the mast plumb left to right. Adjust the 7/8" eyebolts to bring the mast into plumb side to side. Torque the 7/8" nuts to 125 Ft-Lbs. minimum.

The following pages will illustrate and detail the installation of the braces to the mast. Refer to the correct page for the model you are installing. The brace attachment models are as follows:

Models 3102 and 3103 – Page 13

Models 3104, 3105, 3106, 3107, 3108, and 3109 – Page 15

Models 3110 and 3111 – Page 17

Models 3112 and 3113 – Page 17

Models 3114 and 3115 – Page 18

### Front Folding Rear Braced Backstops Brace Installation

Install the swing hinge clamp assembly onto the rear brace overhead pipe. Make sure the clamp is centered on the mast. Torque the 5/8" nuts to the proper torque.

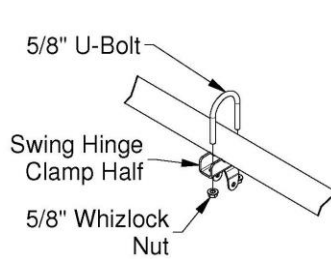

Install the lower mast hinge assembly onto the mast with the center of the U-bolt 129" above the finished floor.

Center the hinge bracket of the clamp on the rear of the mast and in line with the swing hinge.

Torque the 5/8" U-bolt nuts to the appropriate torque.

Slip the slide rod bushing onto the slide rod tube and connect the lower end of the slide rod tube to the mast hinge clamp using the 1/2" x 3-1/2" hex bolt and 1/2" top lock nut.

This nut is NOT torqued to a torque value. Tighten only until the nut comes into contact with the hinge plate. Over tightening this

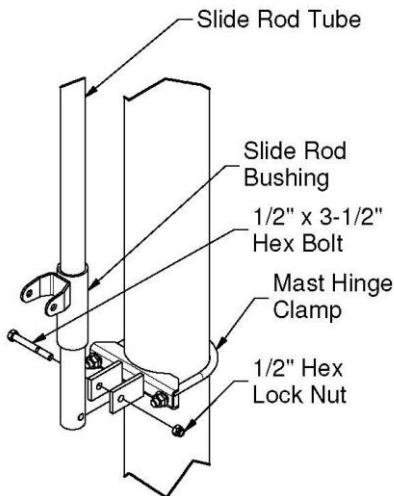
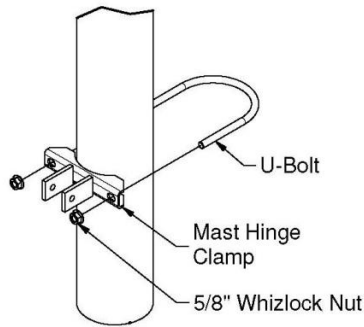
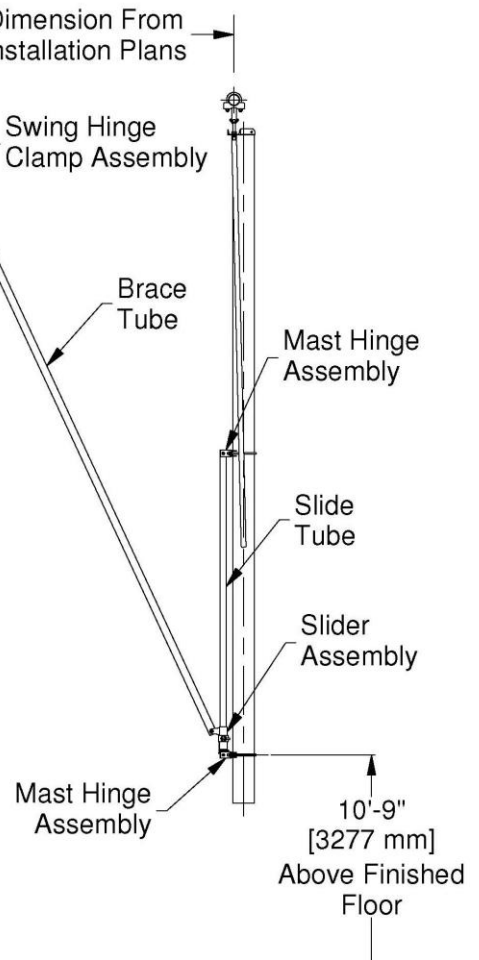

bolt can crimp the slide tube and not allow the slide bushing to move freely.

### Front Folding Rear Braced Backstops Brace Installation (continued)

At the top of the slide tube, install another mast hinge assembly. Connect the mast hinge assembly to the mast and bolt the top of the slide tube to the mast hinge. Tighten bolts as noted in the previous paragraphs for mast hinge and slide tube. Once all bolts and nuts are tightened properly, check to make sure the slide bushing moves freely.

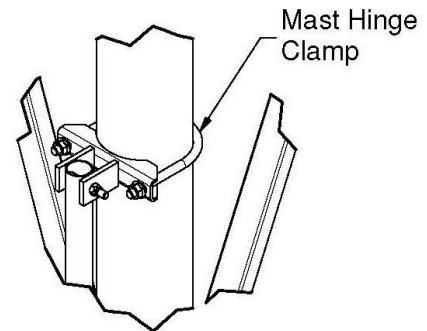

Upper Slide Tube Connection

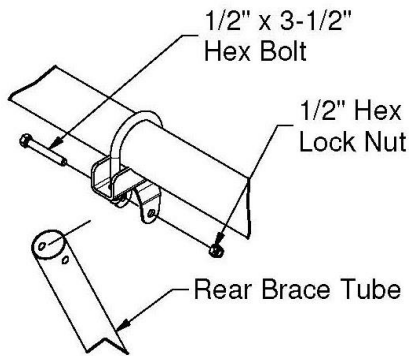

Install the rear brace tube onto the upper swing hinge using a 1/2" x 3-1/2" hex bolt and 1/2" hex top lock nut.

This nut is NOT torqued to a torque value. Tighten only until the nut comes into contact with the hinge plate. Over tightening this bolt can bind the rear brace tube not allowing it to rotate freely.

Attach the lower end of the rear brace tube onto the slide rod bushing using a 1/2" x 3-1/2" hex bolt and 1/2" hex top lock nut.

This nut is NOT torqued to a torque value. Tighten only until the nut comes into contact with the hinge plate. Over tightening this bolt can bind the rear brace tube not allowing it to rotate freely.

Assemble the spring lock clamp onto the slide rod bushing.

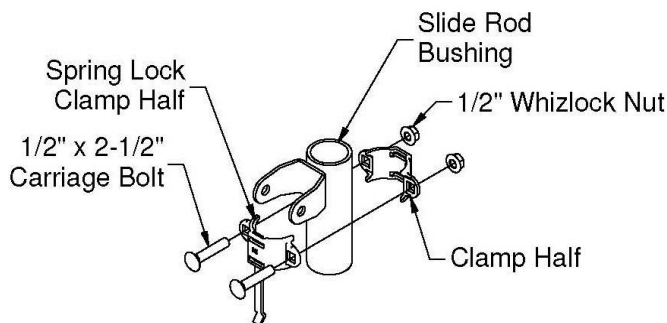
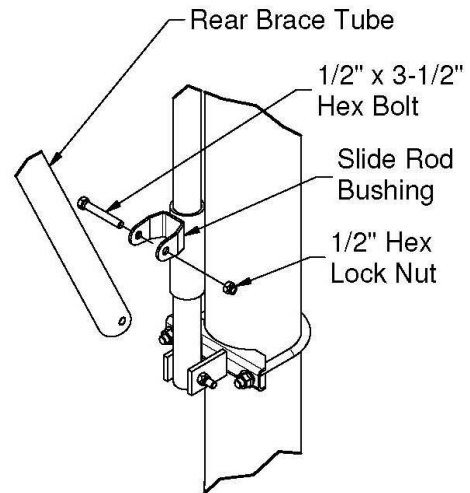

Tighten the whizlock nuts by hand only tight enough to hold the clamp in place for now. It will be re-adjusted once the mast is plumb and the locking muffler clamp is installed.

### Front Folding Rear Braced Backstops Brace Installation (continued)

Place the 1-7/8" muffler clamp onto the slide tube below the slide rod bushing. Tighten by hand.

Pull the mast to the plumb position and support it with the scissor lift, or scaffolding. While the mast is plumb, slide the muffler clamp against the bottom of the slide rod bushing and torque the muffler clamp nuts.

Slide the slide rod clamp down over muffler clamp U-bolt so that the clamp fully seats on the U-bolt, but does not allow for any additional play.

Torque the slide rod clamp nuts.

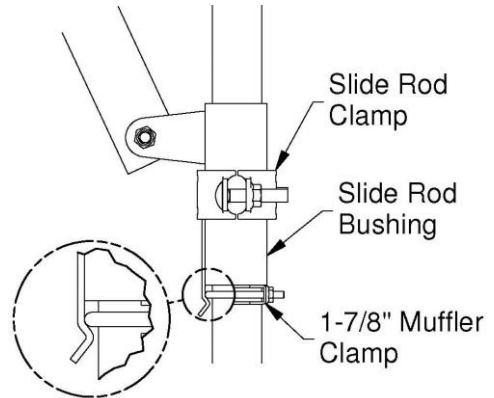

### Folding Brace Backstops Brace Installation

All folding brace backstops (i.e. Front Brace Front Folding, Rear Brace Rear Folding, and Side Brace Side Folding) have the same brace installation procedures. The only difference is location of the braces with respect to the mast.

Install the swing hinge clamp assembly onto the brace overhead pipe. Refer to the installation plans provided for the proper location of the overhead. Make sure the clamp is centered on the mast. Torque the 5/8" nuts to the proper torque.

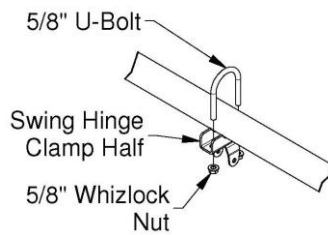

Assemble the brace tubes and folding hinge assembly on the ground. Set the overall length to the dimension shown on your installation prints and center the hinge.

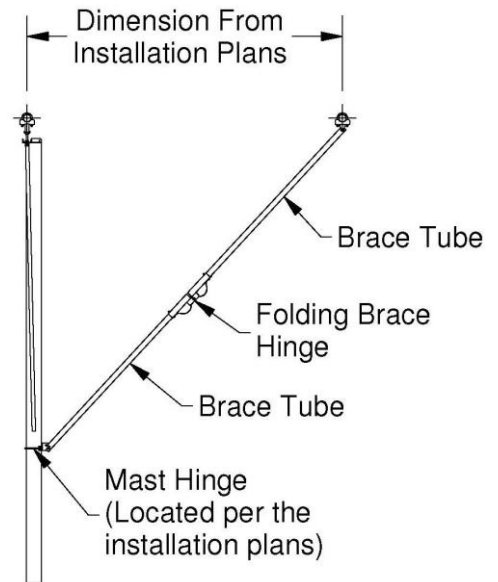
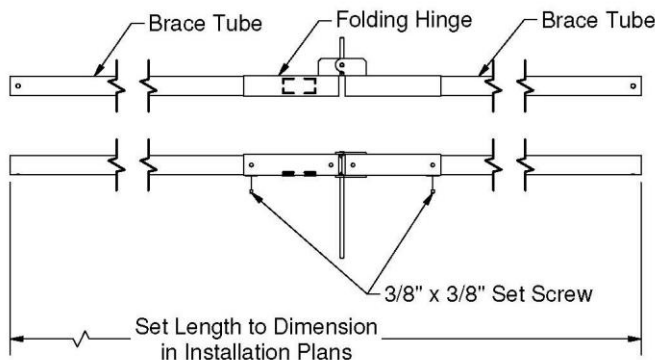

Install the 3/8" set screws in the hinge assembly and tighten to hold the position of the hinge.

Pull the mast to the plumb position and support it with the scissor lift, or scaffolding. While the mast is plumb,

install the mast hinge (with SafeStop bracket if required) assembly onto the mast. Hand tighten 5/8" whizlock nuts only. Install the upper end of the brace to the swing hinge with a 1/2" x 3-1/2" hex bolt and locknut. Install the lower end of the brace to the mast hinge using a 1/2" x 4" hex bolt and locknut. Make sure the breaker bar and hinge is on the underside of the installed brace tube.



Tighten the locknuts of the 1/2" bolts only until the locknut comes into contact with the hinge plate. DO NOT torque these nuts.

Double check the mast is plumb and torque the 5/8" whizlock nuts of the mast hinge to proper torque as listed in the bolt torque chart.

### Folding Brace Backstops Brace Alternate Installation

Install the swing hinge clamp assembly onto the brace overhead pipe. Refer to the installation plans provided for the proper location of the overhead. Make sure the clamp is centered on the mast. Torque the 5/8" nuts to the proper torque.

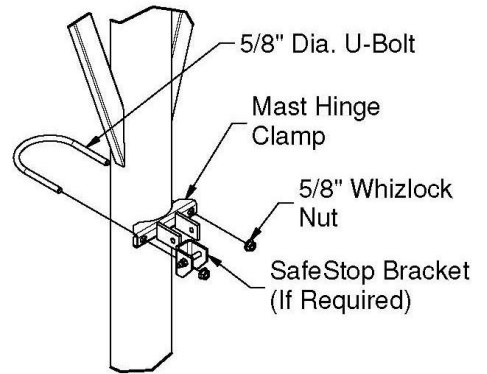
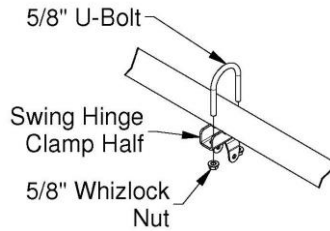

Install the mast hinge assembly onto the mast with the center of the U-bolt located per the dimension from the installation plans above the finished floor. Center the hinge bracket of the clamp on mast and in line with the swing hinge.

Note: If a SafeStop is to be installed on this unit, you must add the SafeStop attach bracket to the mast hinge at this time. If no SafeStop is to be installed, disregard this step.

Install the upper brace tube onto the swing hinge and the lower brace tube onto the mast hinge.

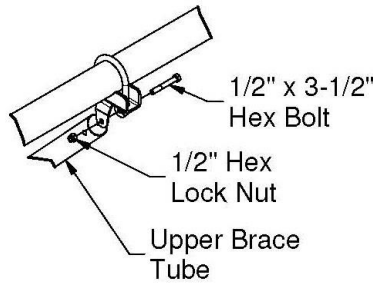

The upper brace tube is connected with a 1/2" x 3-1/2" hex bolt and top lock nut.

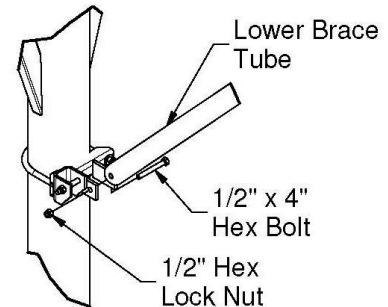

The lower brace tube is connected with a 1/2" x 4" hex bolt and top lock nut.

These nuts are NOT torqued to a torque value. Tighten only until the nut comes into contact with the hinge plate. Over tightening this bolt can bind the brace tube not allowing it to rotate freely.

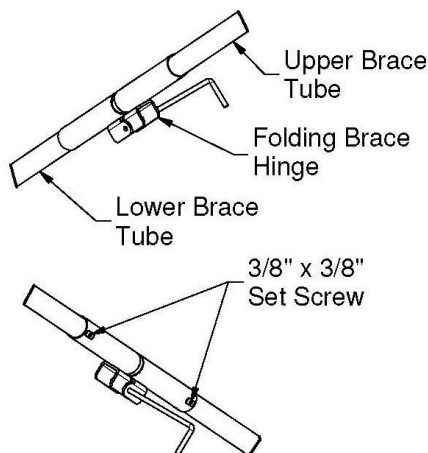

Pull the mast to the plumb position and support it with the scissor lift, or scaffolding. While the mast is plumb, slide the folding brace hinge onto the free ends of the upper and lower brace tube.

The initial adjustment of the hinge is centered between the mast hinge connection point and the swing hinge connection point.

Tighten the 3/8" set screws tight enough to hold the hinge in position.

The final adjustment will be made after the hoist is installed and the lifting cable has been properly installed and routed.

## Rear Brace and Front Brace Stationary Backstops Brace Installation

Install the swing hinge clamp assembly onto the brace overhead pipe. Refer to the installation plans provided for the proper location of the overhead. Make sure the clamp is centered on the mast. Torque the 5/8" nuts to the proper torque.

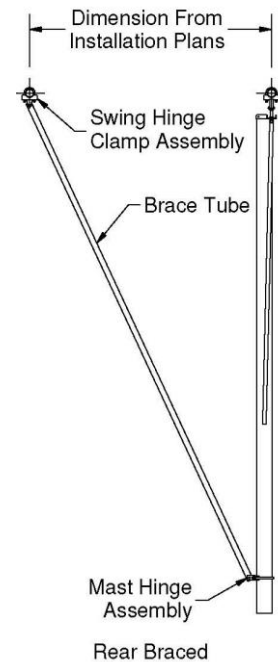
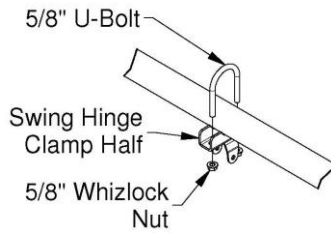

Install the mast hinge assembly onto the mast. Center the hinge bracket of the clamp in line with the swing hinge. Tighten the 5/8" whizlock nuts only enough to hold the clamp in position.

These nuts will be torqued after brace has been installed and the mast adjusted to plumb. It will be necessary to move the mast hinge up or down on the mast to obtain a plumb mast.

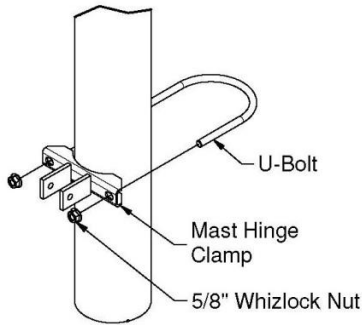

Install the brace tube onto the swing hinge with a 1/2" x 3-1/2" hex bolt and top lock nut.

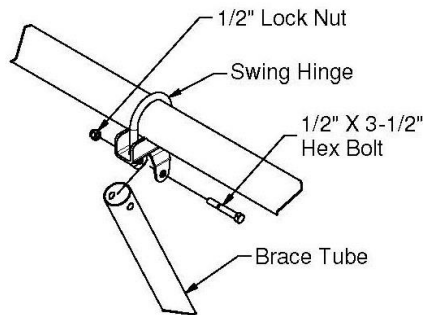

This nut is NOT torqued to a torque value. Tighten only until the nut comes into contact with the hinge plate. Over tightening this bolt can bind the rear brace tube not allowing it to rotate freely.

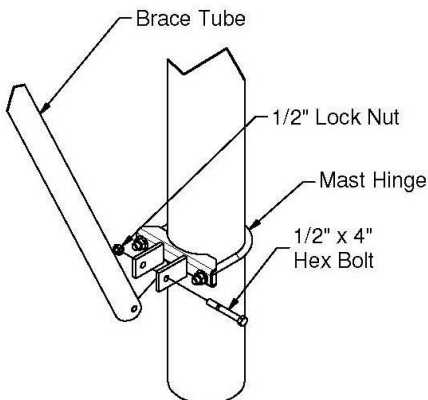
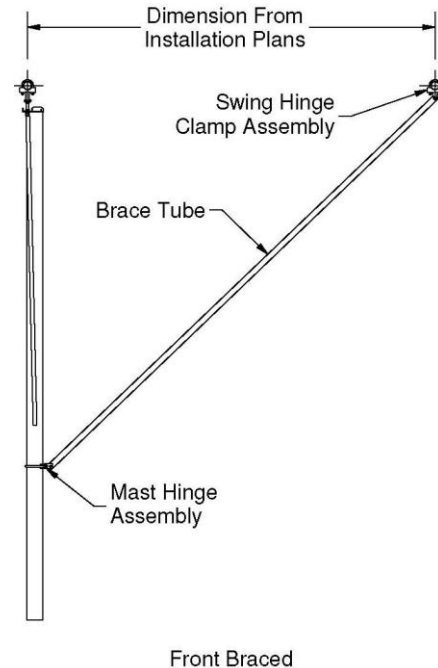

The brace tube is connected to the mast hinge with a 1/2" x 4" hex bolt and top lock nut.

This nut is NOT torqued to a torque value. Tighten only until the nut comes into contact with the hinge plate. Over tightening this bolt can bind the rear brace tube not allowing it to rotate freely.

Pull the mast to the plumb position while sliding the mast hinge up or down on the mast and support it with the scissor lift, or scaffolding. While the mast is plumb, torque the 5/8" mast hinge U-bolt nuts to the appropriate torque.

### Wall Braced Stationary Backstops Brace Installation

Install the mast hinge onto the mast with the center of the U-bolt 129" above the finished floor. Center the hinge bracket of the clamp on the rear of the mast.

Torque the 5/8" U-bolt nuts to the appropriate torque.

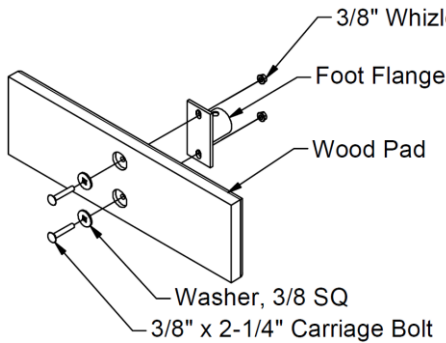
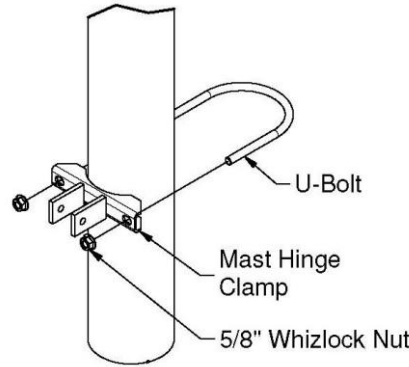

Install the foot flange onto the wood pad using the 3/8" x 2-1/4" carriage bolts, 3/8" square washers, and 3/8" whizlock nuts.

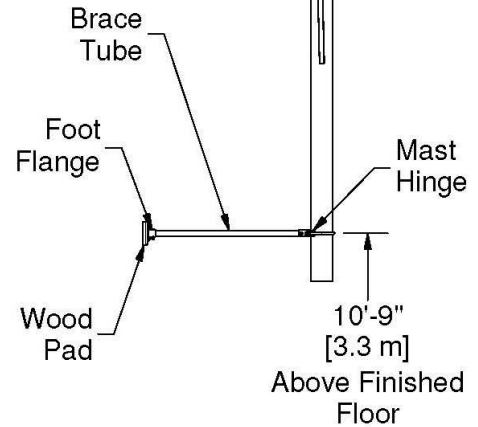

Torque these nuts to 7 – 10 Ft-Lbs. (9 – 14 Nm)

Install the wood pad with the foot flange onto the wall directly behind the mast and the center of the pad 129" above the finished floor. A minimum of 2 anchors is required; however, 4 anchors is preferred. These anchors should be rated for at least 2,000 lbs. pull out strength.

Plumb the mast and measure the distance between the center of the brace tube attachment holes in the foot flange and the mast hinge. Measure the brace tube to verify the hole centers match the distance measured between the foot flange and mast hinge. It may be necessary to adjust the mast on the overhead or modify the length of the brace tube to get the tube dimension to match the distance measured. It is important to have these measurements match in order to keep the mast plumb.

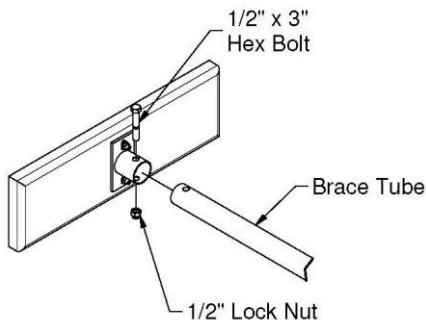

Install one end of the brace tube onto the foot flange using the 1/2" x 3" hex bolt and 1/2" lock nut.

Install the opposite end of the brace tube onto the mast hinge using the 1/2" x 4" hex bolt and 1/2" lock nut.

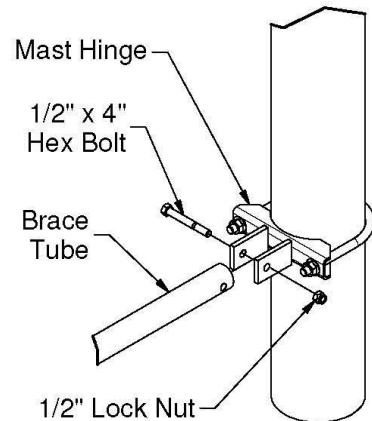

Do not torque these nuts. Tighten only enough to take all slack out of the bolted connection.

## Winch Installation and Cable Routing

Refer to the installation plans for the location and mounting configuration of the winch. Specific installation instructions for the electric hoist are provided in the document 55175510 – Electric Hoist Manual. Be sure and follow all instructions in that document for installing the hoists.

The location of the hoist is specified in the installation plans provided with the job; however, it is important to note if an offset in the routing is required. Refer to the following illustration for offset guidelines.

If the winch cannot be centered on the mast within the width of the cable drum, an offset cable routing should be used.

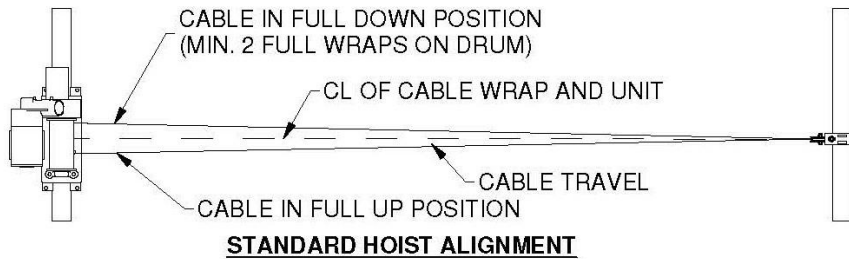
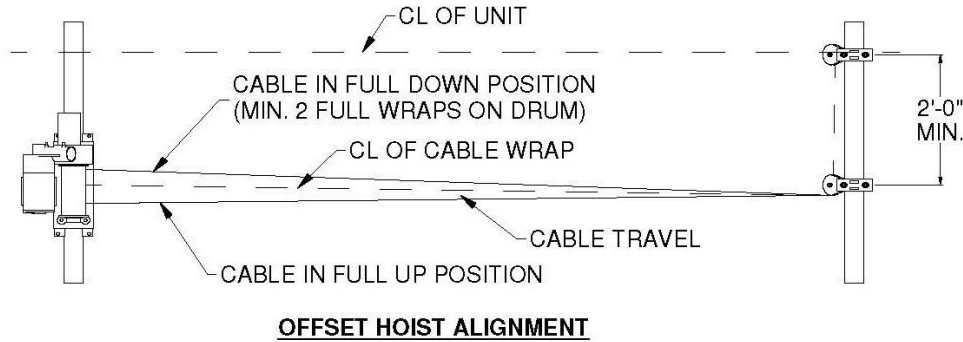

Pulley hangers should be mounted to the overhead pipes at the locations shown on the installation plans and within limits of the fleet angle shown in the winch assembly manual.

Slide the #5 pulley mounting eye onto the U-bolt of the pulley hanger. Install the U-bolt onto the overhead pipe, and into the pulley hanger clamp half. Tighten and torque the whizlock nuts to the appropriate torque.

Cable routing for the forward fold rear braced (i.e. sliding braced) backstops is different than the cable routing for folding braced backstops.

Sliding braced backstop cable routing is shown beginning on page 20.

Folding brace backstop cable routing is shown beginning on page 22.

**Important:** Some larger folding braced units require different cable routing than shown in this manual. Always refer to the cable routing instructions in the installation plans supplied for the specific job.

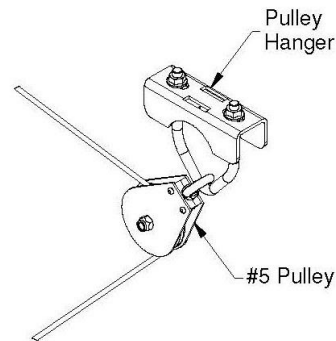

### Sliding Braced Backstop Cable Routing

Install the mast hinge assembly onto the mast with the center of the U-bolt located per the dimension from the installation plans above the finished floor. Center the hinge bracket of the clamp on the front of the mast.

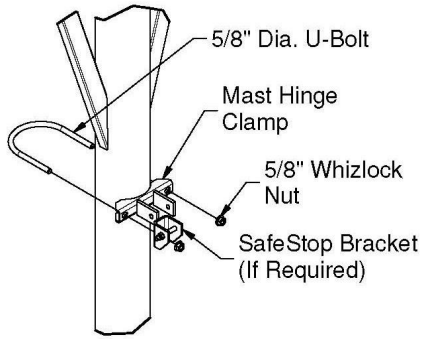

Note: If a SafeStop is to be installed on this unit, you must add the SafeStop attach bracket to the mast hinge at this time. If no SafeStop is to be installed, disregard this step.

#### Hoist Cable Assembly Instructions:

1. Starting at bottom pull-up point on mast, attach cable to hinge clamp with (2) 1/4" cable clamps and (1) 1/4" cable thimble as shown in the illustration.

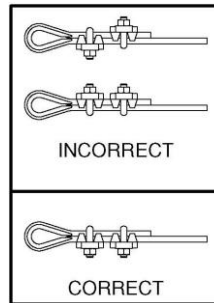
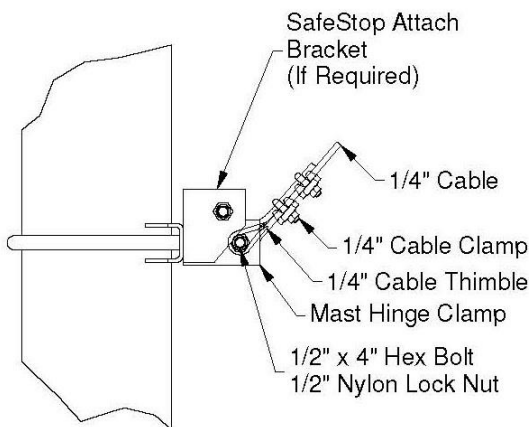

2. Before routing cable through front pull-up pulley, run cable through Small Pulley.
3. Finish by routing cable through front pulley and connecting end of cable to hoist. Allow enough cable for a minimum of two full wraps of cable on the drum.

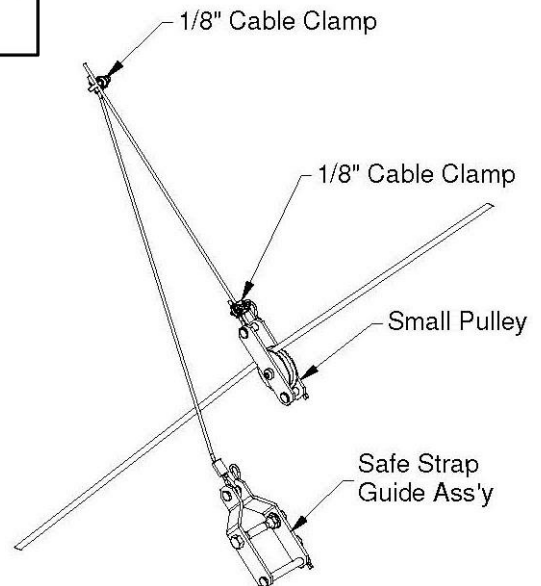
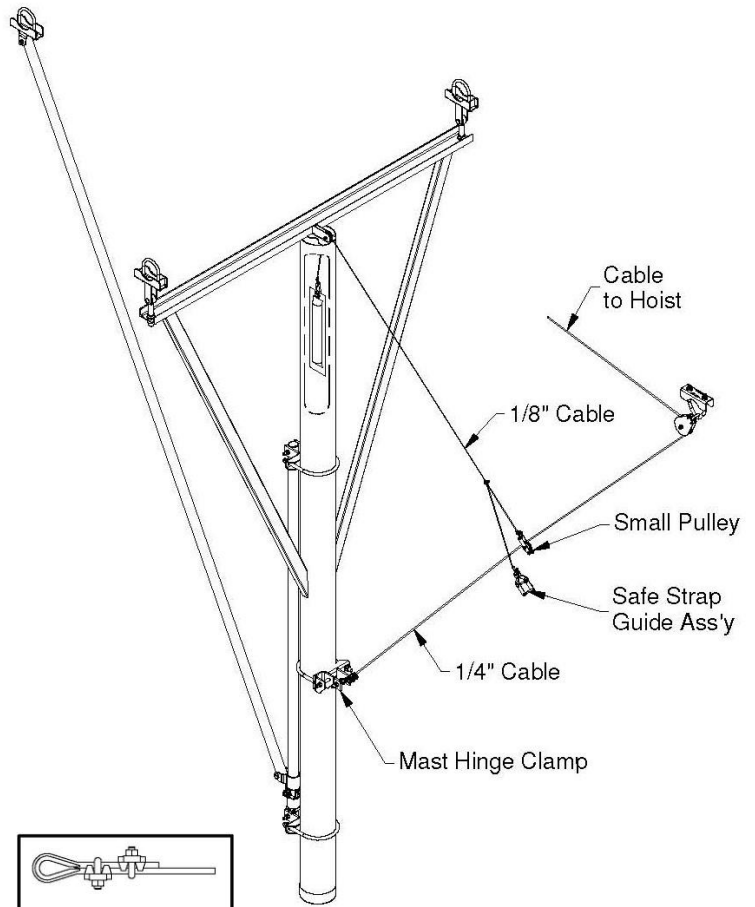

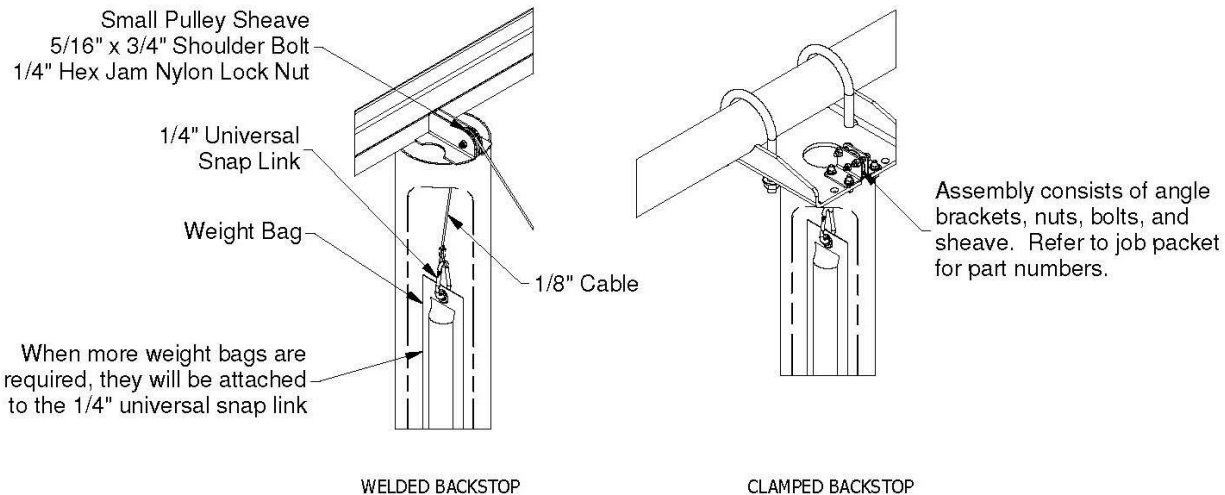

**Retractor Cable Assembly Instructions:**

1. Drop looped cable end down mast, thread un-looped end through pulley, and temporarily secure at top of mast.
2. Attach weighted bag/bags to cable loop at bottom of mast with snap link. See chart below for the number of weight bags required.
3. Pull weights to top of mast with cable and cut cable to length 12" below pull up clamp.
4. Assemble Small Pulley Assembly to pull up cable .
5. Attach 1/8" retractor cable to Small Pulley Assembly, using 1/8" cable clamp to secure.
6. As required, attach Safe Strap Guide Assembly to 1/8" retractor cable. Attach 12" above Small Pulley Assembly using 1/8" cable clamp. Route SafeStop strap though guide.

Weight Bag Requirements			
Unit	Cable Length	Weight Bags w/o SafeStop	Weight Bags w/ SafeStop
18-30 ft	22 ft	1	2
32-38 ft	32 ft	2	3

### Folding Braced Backstop Cable Routing

Drill a 3/8" diameter hole in the mast using the drill template supplied with the installation plans. Remove sharp edges from the hole with a file.

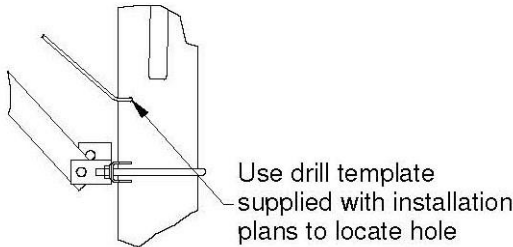

Feed the 1/4" cable through the 3/8" hole until the cable can be seen coming out of the bottom of the mast.

Create a loop in the cable using two (2) 1/4" cable clamps as shown in the illustration to the right and pull the snug against the inside of the mast tube.

Route the cable under the breaker bar on the adjustable hinge.

While keeping the cable clamps snug against the inside of the mast tube, route the cable through the pulley next to the upper brace attachment. Follow the appropriate routing from here to the electric hoist or manual winch. Allow at approx. 36" of extra cable for pre-wrap onto the drum. (2) pre-wrap minimum.

Set the lower limit switch on the electric hoist. Be sure to follow the procedure from the Electric Hoist Manual.

When setting the hoist limit switches, make sure the folding brace is locked in in the full down position. Adjust the lower limit to allow for slack between the 1/4" cable and the breaker bar. **DO NOT** allow more than 1" [25.0mm] slack.

Place warning label 123951579 on mast approx. 3" [76.0mm] below brace arm clamp bolt in position that is visible to users during operation.

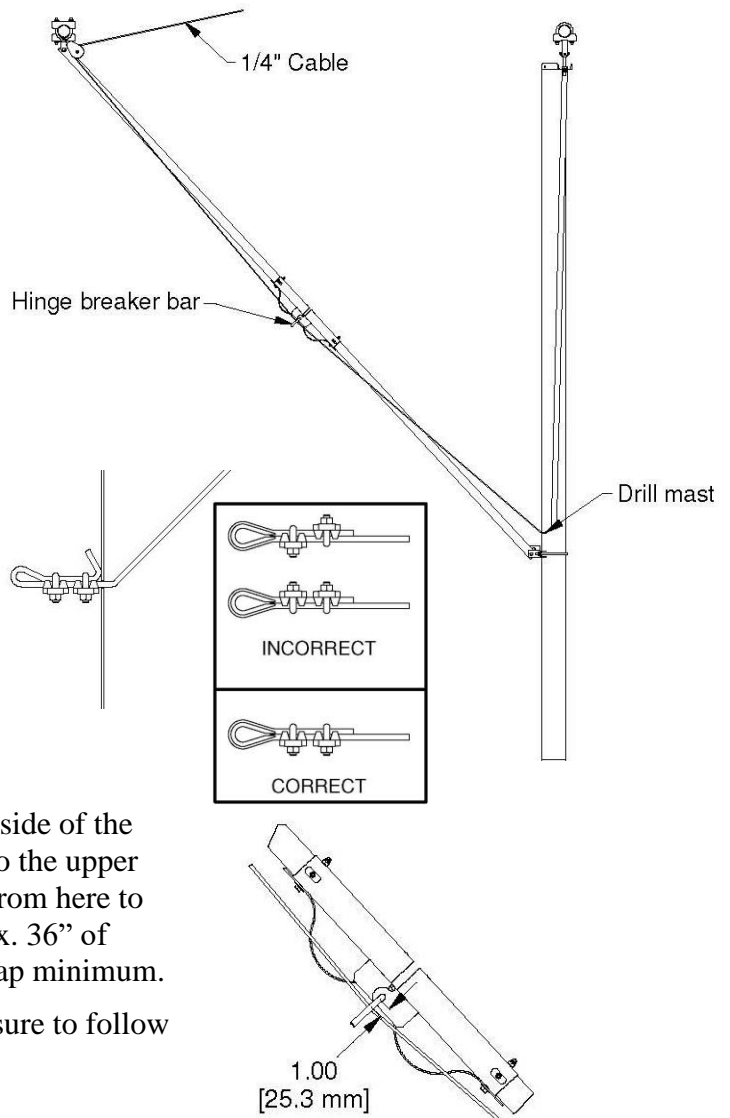

**⚠ WARNING**

DO NOT allow more than 1" [25 mm] slack between the 1/4" cable and the breaker bar when the unit is in the full down position and the hoist has reached the lower limit.

When the slack exceeds 1" [25 mm], the cable could jump over the breaker bar resulting in severe damage to the equipment and severe injury or death.

123951579

### Installing the board and goal to the mast.

Installing a board and goal without a height adjuster is shown beginning on page 23.

Installing a board and goal with a height adjuster is shown beginning on page 25.

## Board and Goal Installation without a Height Adjuster

Some installers prefer to assemble the goal to the backboard on the ground and then install the subassembly to the mast in the air. Others prefer to assemble the board to the mast and then add the goal. Either method is acceptable, but this manual will describe pre-assembling the goal to the board first.

The hardware is different depending on the type of board and type of goal. This manual discusses the most common combination of the LXP glass backboard and breakaway goal. Always check your plans shipped with the product to verify the type of backboard and goal and always follow the plan instructions if different than an LXP board and breakaway goal.

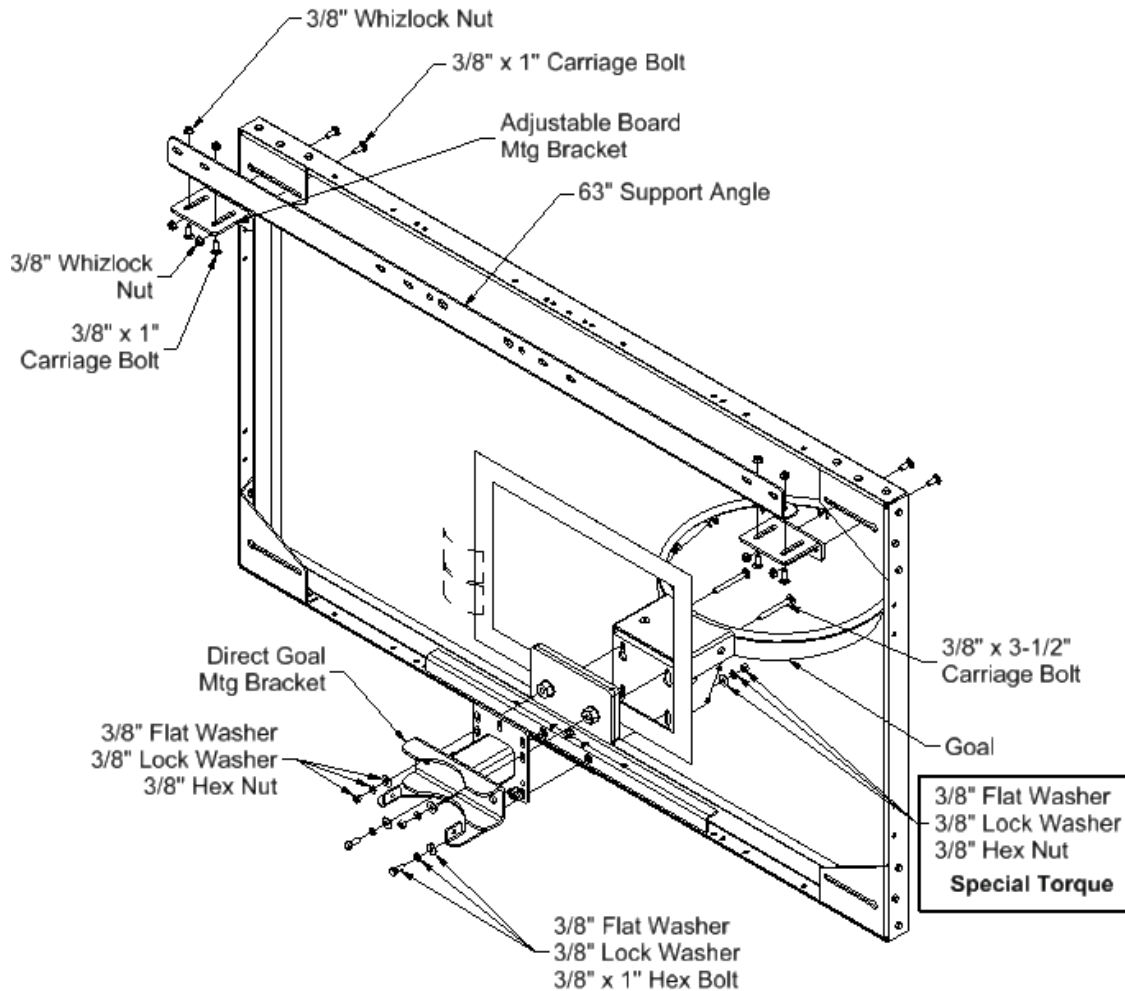

Install the direct goal mounting bracket onto the backboard using the 3/8" x 1" bolts with flat washer and lock washer in the bottom holes of the backboard. Tighten by hand at this time. Slide the 3/8" x 3-1/2" carriage bolts through the upper goal mounting holes. Install a 3/8" flat washer, lock washer, and hex nut onto each bolt but **DO NOT** tighten yet. Slide the goal onto the carriage bolts by slipping the heads through the keyhole slots on the goal and sliding the goal down firmly onto the carriage bolts. Tighten and torque the carriage bolt nuts and the 3/8" x 1" hex bolts mounting the direct goal mounting bracket. Use bolt torque chart values.

Install the flat washer, lock washer, and nut onto the studs at the lower goal mounting slots. Tighten these nuts and torque only to 5.5 to 7.5 Ft-Lbs. [8 to 10 Nm]. Over tightening these nuts may cause the studs to break.



### Board and Goal Installation without a Height Adjuster (Cont'd)

Install the 63" support angle onto the backboard as shown in the illustration on the previous page. Utilize the 3/8" x 1" carriage bolts and whizlock nuts. Tighten the nuts by hand only at this time as adjustments will be required when the board is mounted to the mast.

Install the board and goal sub-assembly onto the mast. When using a scissor lift, set the board and goal sub-assembly on top of the lift and raise the scissor lift to get the board and goal into position. Board and goals can weigh as much as 350 lbs., extreme caution should be taken and make sure there are no personnel underneath.

Install the 5/8" U-bolt onto the direct goal bracket and secure with the 5/8" whiz-lock nuts. Tighten by hand at this point.

Insert the bank mounting clamp between the mast and the support angle. Install the 5/8" U-bolt making sure it is through the bank clamp and the support angle. Secure with the 5/8" whizlock nuts. Tighten by hand at this point.

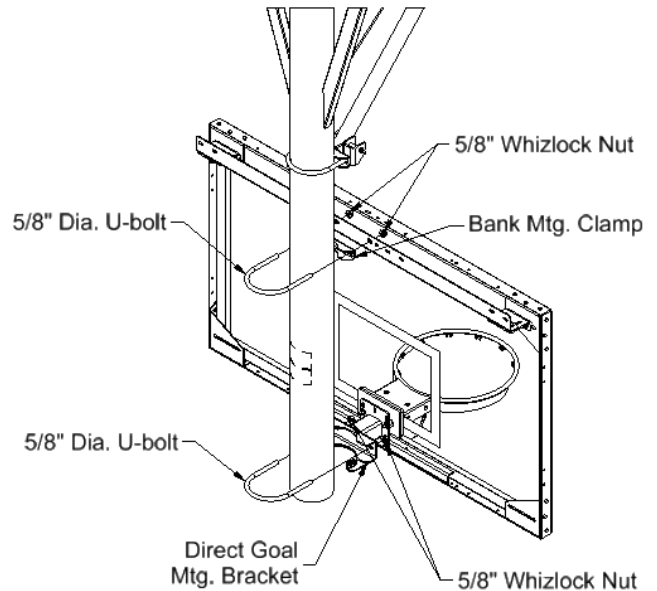

Before removing the support from the board and goal sub-assembly, square the backboard to the court and check the height of the rim to be 120" ± 1/16" from the finished floor. Adjust the board and goal sub-assembly as required to the correct position.

Torque the 5/8" whizlock nuts to 94 to 130 Ft-Lbs. [128 to 176 Nm]. These U-bolt nuts **MUST** be torqued as described to prevent movement of the backboard and goal.

Using a 3/8" diameter bit, drill through the 3/8" hole in the mast clamp and through each side of the mast tube. Install a 3/8" x 1" hex bolt "Stop Bolt" with a 3/8" flat washer under the head and the nut, and a 3/8" nylon lock nut in the hole on both sides of the mast. Torque these nuts to the torque shown in the torque chart.

**⚠ WARNING**

1) The 5/8" mast clamp U-bolt nuts **MUST** be torqued to a value of 94 to 130 Ft-Lbs. [128 to 176 Nm].

2) Stop Bolts **MUST** be installed on each side of the mast clamp after final adjustment. See installation instructions.

Failure to torque the U-bolt nuts to the specified value and/or failure to install the stop bolts could allow the backboard to slip off the mast resulting in serious injury or death.

123951586

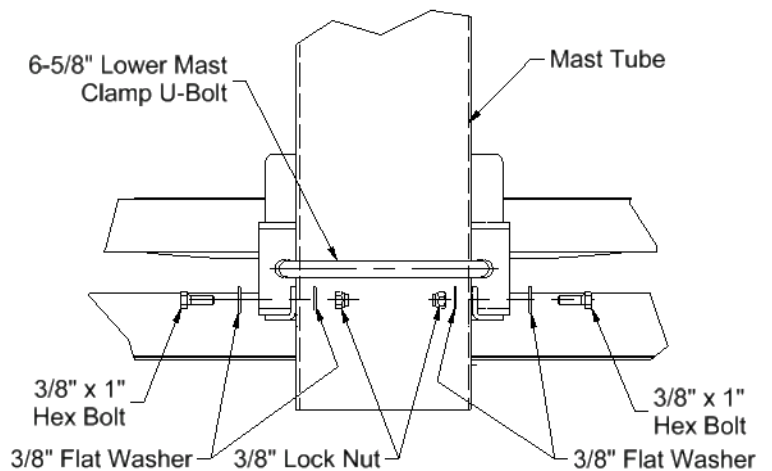

## Board and Goal Installation with a Height Adjuster

Some installers prefer to assemble the goal to the backboard and the backboard to the height adjuster on the ground and then install the subassembly to the mast in the air. Others prefer to assemble the height adjuster to the mast and then add the board and then the goal. Either method is acceptable, but this manual will describe pre-assembling the goal to the board and board to the height adjuster first.

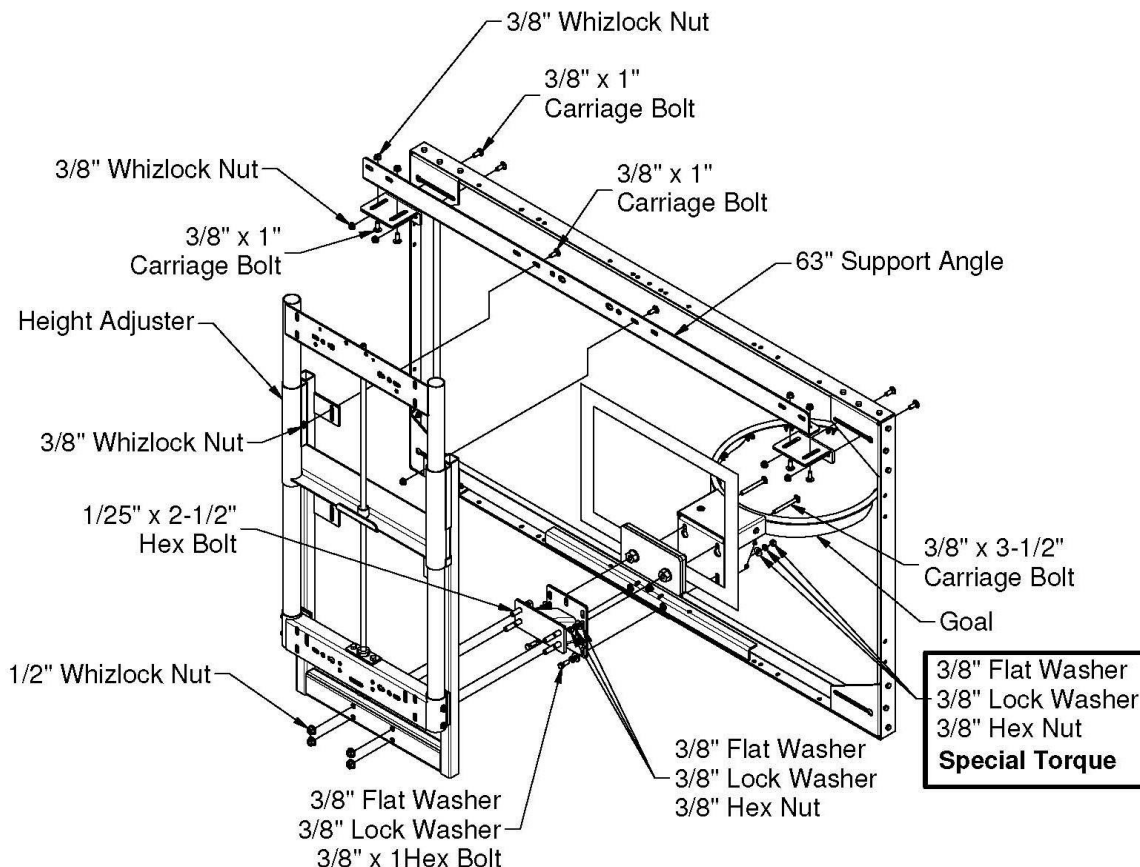

The hardware is different depending on the type of board and type of goal. This manual discusses the most common combination of the LXP glass backboard and breakaway goal. Always check your plans shipped with the product to verify the type of backboard and goal and always follow the plan instructions if different than an LXP board and breakaway goal.

Install the direct mount extension onto the backboard using the 3/8" x 1" bolts with flat washer and lock washer in the bottom holes of the backboard. Tighten by hand at this time. Slide the 3/8" x 3-1/2" carriage bolts through the upper goal mounting holes. Install a 3/8" flat washer, lock washer, and hex nut onto each bolt but **DO NOT** tighten yet. Slide the goal onto the carriage bolts by slipping the heads through the keyhole slots on the goal and sliding the goal down firmly onto the carriage bolts. Tighten and torque the carriage bolt nuts and the 3/8" x 1" hex bolts mounting the direct goal mounting bracket. Use bolt torque chart values.

Install the flat washer, lock washer, and nut onto the studs at the lower goal mounting slots. Tighten these nuts and torque only to 5.5 to 7.5 Ft-Lbs. [8 to 10 Nm]. Over tightening these nuts may cause the studs to break.

### Board and Goal Installation with a Height Adjuster (Cont'd)

Install the 63” support angle onto the backboard as shown in the illustration on the previous page. Utilize the 3/8” x 1” carriage bolts and whizlock nuts. Tighten the nuts by hand only at this time as adjustments will be required when the assembly is mounted to the mast.

Attach the height adjuster to the board and goal assembly by bolting the direct mount extension to the lower height adjuster tube using four (4) 1/2” x 2-1/2” hex bolts and 1/2” whizlock nuts. Torque these bolts to the torque listed in the bolt torque chart.

Attach 63” support angle to the tabs on the height adjuster using the 3/8” x 1” carriage bolts and 3/8” whizlock nuts. Torque these nuts to the torque listed in the bolt torque chart.

Before attaching the height adjuster to the board and goal assembly, make sure the height adjuster is at the full “UP” position. Manual height adjusters can be cranked to the full up position. Electric height adjusters should be set from the factory, but can be adjusted with temporary power if required.

Install the board and goal and height adjuster sub-assembly onto the mast. When using a scissor lift, set the sub-assembly on top of the lift and raise the scissor lift to get the board and goal into position. Board, goal, and height adjusters can weigh as much as 450 lbs., extreme caution should be taken and make sure there are no personnel underneath.

On the lower height adjuster frame, insert the AAG Mount Clamp (with the long flange down) between the mast and the lower height adjuster frame. Install the 5/8” U-bolt onto the mast and through the AAG mounting clamp and height adjuster frame and secure with the 5/8” whiz-lock nuts. Tighten by hand at this point.

On the upper height adjuster frame, insert the Bank Mounting Clamp between the mast and the lower height adjuster frame. Install the 5/8” U-bolt onto the mast and through the Bank Mounting Clamp and height adjuster frame and secure with the 5/8” whiz-lock nuts. Tighten by hand at this point.

Before removing the support from the board and goal sub-assembly, square the backboard to the court and check the height of the rim to be 120” ± 1/16” from the finished floor. Adjust the board and goal sub-assembly as required to the correct position.

Torque the 5/8” whizlock nuts to 94 to 130 Ft-Lbs. [128 to 176 Nm]. These U-bolt nuts **MUST** be torqued as described to prevent movement of the backboard and goal.

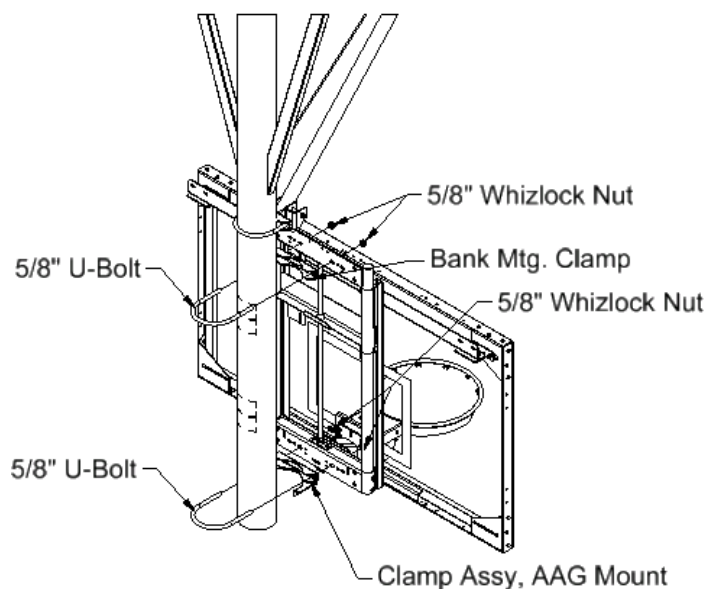

<b>⚠ WARNING</b>
<p>The 5/8" mast clamp U-bolt nuts <b>MUST</b> be torqued to a value of 94 to 130 Ft-Lbs. [128 to 176 Nm].</p> <p>Failure to torque the U-bolt nuts to the specified value could allow the backboard to slip off the mast resulting in serious injury or death.</p>
123951581

Using a 3/8" diameter bit, drill through the 3/8" holes in the AAG Mount (lower) Mast Clamp and through each side of the mast tube. Install a 3/8" x 1" hex bolt "Stop Bolt" with a 3/8" flat washer under the head and the nut, and a 3/8" nylon lock nut in the hole on both sides of the mast. Torque these nuts to the torque shown in the torque chart

**⚠ WARNING**

Stop Bolts **MUST** be installed on each side of the mast clamp after final adjustment. See installation instructions.

Failure to install these bolts could allow the backboard to slip off the mast resulting in serious injury or death.

123951584

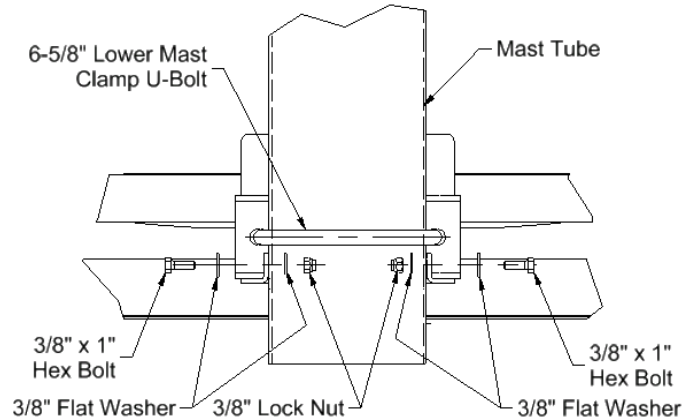

### Folding Brace Adjustment and Setting the Limit Switches

Connect temporary power to the electric hoist and raise the backstop while watching the folding brace position with respect to the mast. As the mast approaches the desired full up position if the lower brace is not parallel to the mast or the upper brace is not parallel to the ground, the brace must be adjusted.

As a general rule, when the backstop is fully raised, the lower brace should be parallel to the mast while the upper brace is parallel to the floor. Adjustments should be made as noted in the following illustrations.

To adjust the braces, loosen the 3/8" set screws on the side of the hinge and slide the hinge on the brace pipes to obtain the correct adjustment of the braces.

To keep the mast position correct, shorten one side the same distance that you lengthen the other.

Once the correct adjustment has been achieved, tighten the set screws and mark the end of the hinge on each brace tube section in case the hinge slips during the next few steps.

Before lowering the backstop, set the upper limit on the electric hoist.

Refer to 551755510 – Electric Hoist Manual for the correct procedure of setting the limits.

Once the upper limit has been set, lower the backstop to the full down position and check the mast to make sure it is plumb.

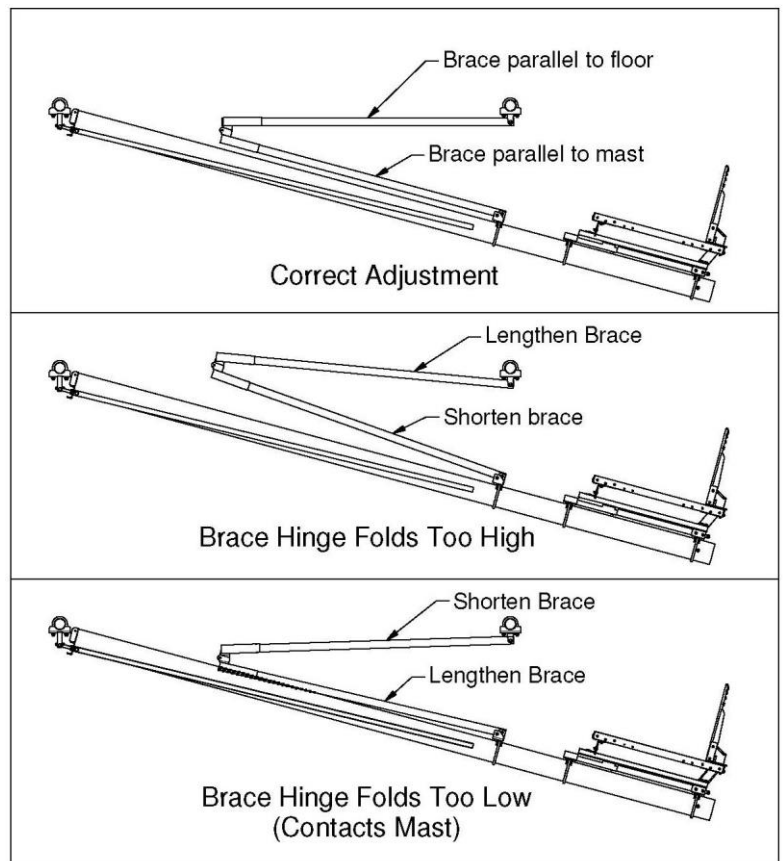

## Folding Brace Adjustment and Setting the Limit Switches (Cont'd)

Set the lower limit switch on the electric hoist. Be sure to follow the procedure from the Electric Hoist Manual.

Make sure the folding brace is locked in in the full down position. Adjust the lower limit to allow for slack between the 1/4" cable and the breaker bar. DO NOT allow more than 1" [250mm] slack.

Double check the marks on the brace hinge to make sure it has not moved during the lowering of the backstop.

Using the holes in the hinge as a guide, drill a 13/32" diameter hole through the brace tube at both ends of the hinge.

Slide one end of the folding hinge safety strap between the hinge pivot bar and the hinge.

Install a 3/8" flat washer onto the 3/8" x 3-1/2" hex bolt and then slide the bolt through the grommet hole in the safety strap. Install the bolt in the hinge half through the newly drilled hole in the brace tube and secure with the 3/8" nylon lock nut. The proper torque for these nuts is 7.5 to 11 Ft-Lbs. [10-15 Nm].

Raise and lower the backstop 2 or 3 times to check the limit switches are set correctly and the brace adjustment is correct.

Recheck all bolted connections for proper torque.

### Trim Mast

Due to variations in building truss heights, the masts are sometimes longer than required and must be trimmed in the field.

Using a portable band saw or similar cutoff device, trim the end of the mast to the following dimension:

9'-4" when there is no height adjuster and only a board and goal.

9'-6" when a height adjuster is used in conjunction with the board and goal.

After the mast has been trimmed, install the vinyl end cap onto the bottom of the mast.

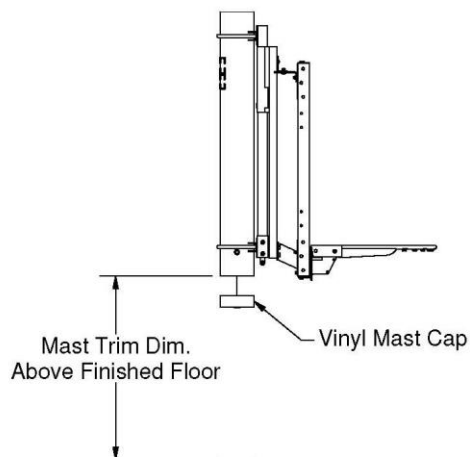
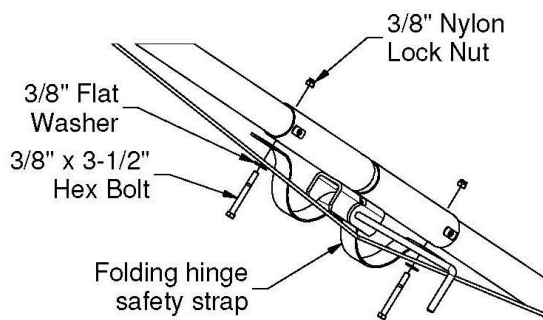
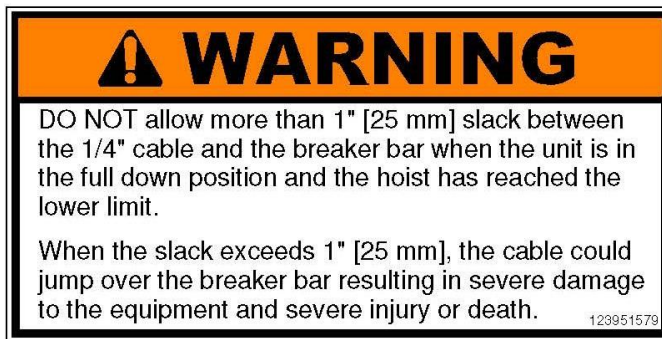

**ATTENTION: INSTALLER**

To confirm that you have received all the parts, and to better serve you if you contact us, please fill out the following information and fax or mail to the address below.

Please refer to the facility name and/or the installation company below when you contact the factory, and include it on any correspondence.

Please complete the checklist on the following page for each unit installed and include them with the fax or letter.

Facility/School Name: \_\_\_\_\_

Installation Date: \_\_\_\_\_

Installed by: \_\_\_\_\_ ASTM #: \_\_\_\_\_

Signature: \_\_\_\_\_ Date: \_\_\_\_\_

Fax to: 1-317-774-9841

Attn: Customer Service

Or

Mail to:

Customer Service

9200 E. 146<sup>th</sup> St., Ste. A

Noblesville, IN 46060

800-848-8034

## Backstop Installation Checklist

Date: \_\_\_\_\_

	Unit Number					
	1	2	3	4	5	6
Building structure has been approved for unit loads.	—	—	—	—	—	—
Overhead structure is installed per the manufacturers Installation plans.	—	—	—	—	—	—
Board and goal are level, plumb and set at appropriate FOB (Face of Bank).	—	—	—	—	—	—
Goal height is correct.	—	—	—	—	—	—
Mast clamps have been torqued to 94 – 128 Ft-Lbs. [128 - 176Nm]	—	—	—	—	—	—
Mast Stop Bolts have been installed through Mast Clamp and Mast Tube on each side of clamp..	—	—	—	—	—	—
Hardware is tight.	—	—	—	—	—	—
Quick links have been closed and tightened.	—	—	—	—	—	—
Height adjuster, if so equipped, is lubricated and operates smoothly.	—	—	—	—	—	—
Key switch or keypad is not located directly behind the folding unit.	—	—	—	—	—	—
Manual winch, if so equipped, is not located directly behind the folding unit.	—	—	—	—	—	—
Beam clamps are installed correctly	—	—	—	—	—	—
Mast hinge quick pin is installed and fully seated on. The clevis pin.	—	—	—	—	—	—
See height adjuster, board, and goal for additional installation instructions and checks.						

## Operating Instructions

Please read these instructions to familiarize yourself with the type of equipment you have purchased. Unauthorized or untrained users can damage even the safest equipment. We strongly recommend that only qualified and authorized personnel be designated as the operators of this equipment.

Authorized personnel is defined as an individual who has been trained for the proper operation of the unit and is sanctioned by the facility as being responsible for the operation of the equipment. The authorized person should be of sufficient age and experience to fully understand and comprehend operation of the equipment.

Even though great care has been taken to ensure the safety of these backstops, mechanical problems or failures can occur. It is VERY important that the authorized operator keep the moving backstops in FULL VIEW AT ALL TIMES. Should the limit switches ever fail to stop the unit in the up or down position, the operator must be prepared to manually halt the unit by releasing the key switch, wireless remote button or keypad button to avoid damage to the facility structure. If a limit switch fails, contact the manufacturer or the responsible installation company. Do NOT continue to operate backstop until limit switch problem has been corrected. If, at any time during operation, any component of the unit fails (such as cables, clamps, pulleys, fittings, attachment points or pipe) STOP THE OPERATION IMMEDIATELY. Contact the manufacturer or the responsible installation company.

To raise or lower your backstop – make sure unit is in full view of authorized operator at all times and area directly below and around backstop is free and clear of people and obstructions.

### *Manual Winch Operation:*

Turn hand crank of manual winch in appropriate direction until backstop is completely raised or lowered.

**IMPORTANT: Limit switches and mechanical stops are NOT used with a manual winch. The authorized operator must keep backstop in full view at all times during operation to ensure correct stopping points.** It may be helpful to use a visual guide, such as marking the cable, to assist in locating the stopping points.

### *Manual Winch with Electric Winch Winder Operation:*

Remove hand crank from winch. Insert socket onto electric winch winder and into

$\frac{3}{4}$ " square crankshaft on face of winch. Operate winch winder in appropriate direction. **Only authorized personnel should operate electric winch winder as structural damage and/or personal injury can occur with unauthorized or untrained users.**

### *Key Switch Operation:*

Turn key in appropriate direction (right=up, left=down) and hold key in position until unit is completely raised or lowered based on preset limit switch stops. The motor will automatically stop when the limit switch engages, even if the key is still turned in the up or down position. The electric hoist provided by the manufacturer is equipped with an instant reverse feature. This feature allows the user to instantly reverse the direction of the backstop with a simple change of key position. HOWEVER, never purposely or quickly reverse the operation without



momentarily stopping in the “neutral” position, as this may cause gear damage, circuit overload or damage to the limit switches.

***Wireless Remote Operation:***

Based on preprogrammed settings, use arrow keys to select desired backstop to be operated. Choose “raise” or “lower”, push button in and hold down until backstop is in position. Repeat procedure for each backstop until all units are in the desired positions.

***Keypad Operation:***

Enter access code; select preprogrammed setups or individual backstops to be operated. Push in and hold “up” or “down” button until backstop is in desired position. Repeat procedure for remaining backstops to be operated. Keypad will automatically shut off after 30 seconds of non-use.

***Electric or Manual Height Adjusters:***

If your backstop has a manual or electric height adjuster – operate the height adjuster via the chosen method (manual crank handle, power wand, key switch or keypad) by raising or lowering to desired level as shown on the height sticker on the side of the unit.

**When raising the backstop to the “up” or storage position, make sure the height adjuster has been raised to the regulation 10’ height.**

If your backstop is a rear-braced forward folding model, the slide rods should be cleaned and lubricated by a qualified individual. A dry silicon lubricant is recommended.

Manual and electric height adjusters should have the slide rods cleaned and lubricated to ensure smooth operation. A dry silicon lubricant is recommended.

NEVER jump, hang, swing from or pull on the backstop structure. This can cause structural damage and/or personal injury.

NEVER place foreign objects on or around the backstop.

NEVER use the backstop for anything other than its intended purpose.

MAINTENANCE INFORMATION – PLEASE RETAIN FOR FUTURE REFERENCE!!!

**MAINTENANCE OVERVIEW**

**!!!ALWAYS DISCONNECT POWER SOURCE BEFORE PERFORMING ANY MAINTENANCE CHECK OR OPERATION ON THIS EQUIPMENT!!!**

The manufacturer recommends an annual maintenance inspection of this equipment by an authorized and trained individual. Inspections should occur more frequently depending upon the usage of the equipment.

It is recommended to use the “Maintenance Checklist” on the following pages as a guide to assist with the inspection. Any item that is not satisfactory should be repaired or replaced immediately.

1. Inspect all bolted connections for proper tightness. Use the bolt torque chart at the right as a guideline for proper torques.

The bolts that secure hinged joints have nylon locking nuts and these should NOT be torqued to the value in the chart. These nuts should only be tightened until the nut just engages the hinge bracket. Do not overtighten the nut as this will cause binding and excessive wear on the joint.

RECOMMENDED BOLT TORQUE			
BOLT SIZE	WRENCH SIZE	In-Lbs	Ft-Lbs
1/4	7/16	66 to 90	5.5 to 7.5
5/16	1/2	132 to 180	11 to 15
3/8	9/16	234 to 318	19.5 to 26.5
7/16	1 1/16		31 to 42.5
1/2	3/4		47 to 65
9/16	7/8		68 to 90
5/8	1 5/16		94 to 130
3/4	1 1/8		166 to 230
7/8	1 5/16		269 to 372
1	1 1/2		402 to 566

Another exception is the studs on the glass backboards that connect the bottom of the goal to the backboard and the bottom of the backboard to the mast attachment bracket. These nuts should only be torqued to 5.5 to 7.5 Ft-Lbs. [8 to 10 Nm]. Over tightening these nuts may cause the studs to break

2. Inspect all backstop fittings for cracks, corrosion, and tightness.
3. Inspect hinge fittings and lubricate as required.
4. Inspect the U-bolts that attach the backboard or height adjuster to the mast. Make sure these U-bolt nuts are torqued to 94 Ft-Lbs. [128 Nm] minimum.
5. Make sure the Stop Bolts, on each side of the lower Mast Clamp, are installed and tight.
6. Check hoist cable for wear and fraying and pulleys for signs of wear. A noisy pulley should be replaced..
7. Inspect the winch for proper operation and make sure limit switches are working and set correctly. Lower the backstop and check the cable droop below the folding hinge breaker bar. If the droop is more than 1” [25 mm], adjust the lower limit switch.
8. If your backstop is a rear-braced forward folding model, the slide rods should be cleaned and lubricated by a qualified individual. A dry silicon lubricant is recommended.
9. Manual and electric height adjusters should have the slide rods cleaned and lubricated to ensure smooth operation. A dry silicon lubricant is recommended.
10. Check the SafeStop for signs of wear. If a yellow or red flag is appearing at the bottom of the strap, SafeStop should be replaced.

**ATTENTION: MAINTENANCE DEPARTMENT**

To confirm that you have received maintenance and warranty information, and to better serve you if you contact us, please fill out the following information and fax or mail to the address below.

Please refer to the facility name and/or the installation company below when you contact the manufacturer, and include it on any correspondence.

I have received the maintenance and warranty information provided by the manufacturer on the ceiling suspended backstop.

Facility/School Name: \_\_\_\_\_

Installation Date: \_\_\_\_\_ Installed by: \_\_\_\_\_

Maintenance Dept. Contact: \_\_\_\_\_

Signature: \_\_\_\_\_ Date: \_\_\_\_\_

Fax to: 1-317-774-9841  
Attn: Customer Service

Or

Mail to:  
Customer Service  
9200 E. 146<sup>th</sup> St., Ste. A  
Noblesville, IN 46060  
800-848-8034

## ***Maintenance Check Sheet***

Refer to the Maintenance Overview section (page 33) for recommended frequency of inspections.

**Date:** \_\_\_\_\_

**Unit:** \_\_\_\_\_

### **Overhead Structure**

-Overhead pipes: dents, stress spots, etc.     OK     Repair     Replace

-Beam clamps     OK     Repair     Replace

### **Unit Supports / Brackets / Hinges**

-Tubes; dents, stress spots, etc.     OK     Repair     Replace

-Bolts; loose, deformed, etc.     OK     Repair     Replace

-Brackets/Hinges; bent, not rotating, etc.     OK     Repair     Replace

-Mast clamp U-bolts for board / Height Adjuster torqued to 94 to 130 Ft-Lbs. [128 to 176 Nm].     OK     Repair     Replace

-Mast Stop Bolts installed and tight.     OK     Repair     Replace

-Sliding brace (if equipped) lubricated.     OK     Repair     Replace

### **Board & Goal**

-Bank padding in good condition     OK     Repair     Replace

-Nets not frayed or torn     OK     Repair     Replace

-Hardware tight.     OK     Repair     Replace

### **Height Adjuster (If Equipped)**

-Lubrication     OK     Repair

### **Manual Winch (If Equipped)**

-Cable wrap smooth and even     OK     Repair

-Operates smoothly     OK     Repair

### **Electric Winch (If Equipped)**

-Cable wrap smooth and even     OK     Repair

-Limits set correctly and operate     OK     Repair

-Operates smoothly no abnormal noise     OK     Repair



**Gared Performance Sports Systems**

**9200 E. 146<sup>th</sup> Street  
Noblesville, IN 46060**

**800-848-8034  
[www.garedperfsports.com](http://www.garedperfsports.com)**